



SV82399A

Vehicle Control Unit

V1.1

Datasheet

Contact Us:

Web: <http://www.ecotron.ai>

Email: info@ecotron.ai
support@ecotron.ai

Address: 2942 Columbia St
Torrance, CA 90503
United States

Tel: +1 562-758-3039
+1 562-713-1105

Table of Contents

CHAPTER 1 SYSTEM INTRODUCTION	4
1.1 Functions.....	4
1.2 Mechanical Properties	5
1.3 Tech Specs	6
1.4 Recommended Software Tools.....	7
1.5 Power Supply	7
1.6 Description of Bootloader	7
CHAPTER 2 TECHNICAL PERFORMANCE	8
2.1 Electrical Characteristics	8
2.2 Electrical PerformanceStandard	9
2.3 Environmental Standards	10
2.4 EMC Test Standard	11
CHAPTER 3 INSTALLATION REQUIREMENTS	12

Chapter 1 System Introduction

ZCU (Zonal Control Unit) is the master controller for electric vehicles.

The ZCU receives the driver's input signals, such as pedal signals, vehicle speed signals, gear signals, and other input signals. The ZCU coordinates the motor, battery pack, and other accessory systems to meet the driving torque requirements. The ZCU implements fault diagnosis and processing, vehicle status monitoring, vehicle mode conversion and other functions.

The ZCU is the vehicle network control or main control unit based on CAN bus network.

1.1 Functions

SV82399A has the following functions:

Functions
1 – key signal (KEYON)
2 – hardwired wake-up signal (WAKE_INPUT_1, WAKE_INPUT_2)
1 – Power Supply Voltages (BATT_SYSTEM)
4 – 5V output
6 – CAN communication interface: CANA supports arbitrary frame wake-up, CANB supports specific frame wake-up
2 – LIN communication interface: LIN2 can be configured as master and slave, supports wake-up
4 – SENT input
4 – RTD input
4 – Hall input
2 – VR sensor input
2 – 10/100Mbps Automotive Ethernet interface
4 – H-bridge output: can be configured as 4 Peak Hold or 8 High-side output and 8 Low-side output
26 – digital signal input: 4 can be configured as rescue mode, 4 have hardware pull-up/pull-down resistors and can be configured as active-high or active-low, 12 can be configured as active-high or active-low, 6 can be configured as active-low

30 – analog signal input: 30 have pull-up resistors, can be configured as 0-32V inputs (pull-up to BATT) or 0-5V inputs (pull-up to 5V), 30 have pull-down resistors, can be configured as 0-32V inputs (support 12/24V system)

8 – frequency signal input

20 – high-side driver control output: all can be configured as PWM output

16 – low-side driver control output: all can be configured as PWM output

PLC – CP, PP, PE output (optional)

Hardware watchdog

1.2 Mechanical Properties

The housing of the ZCU is die-cast aluminum and assembled with a silicone seal. There is no special treatment or plating on the outside of the housing, no sharp burrs, and sharp edges. The nominal dimensions of the housing shape of the ZCU are as follows (excluding the female end of the ZCU connector, in mm):

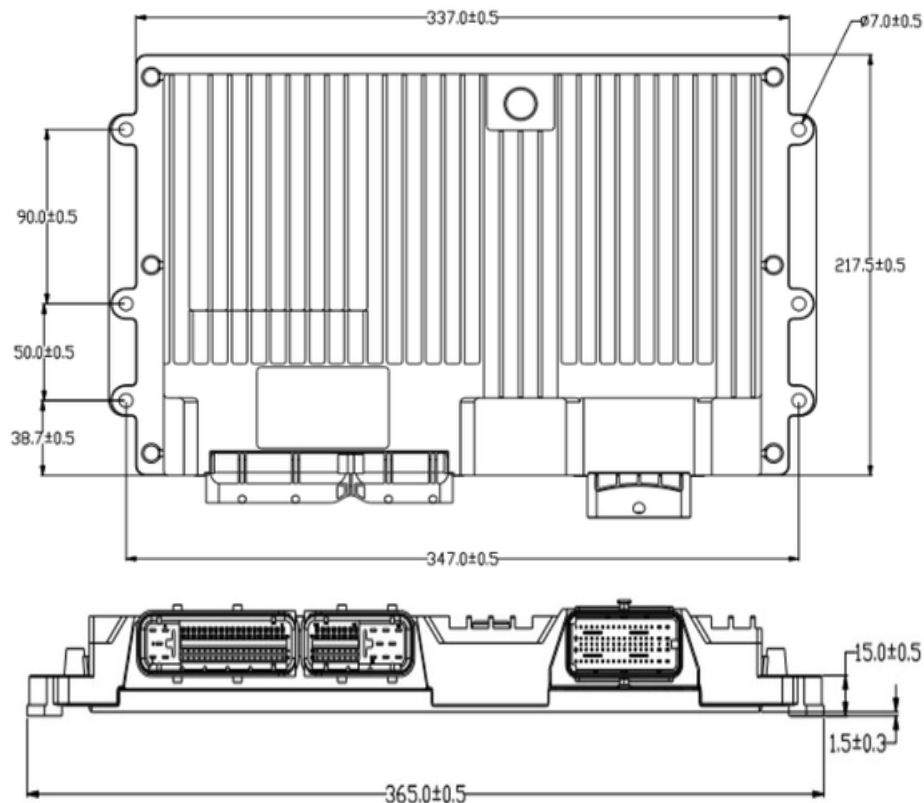

Copyright ECOTRON CORPORATION
All Rights Reserved

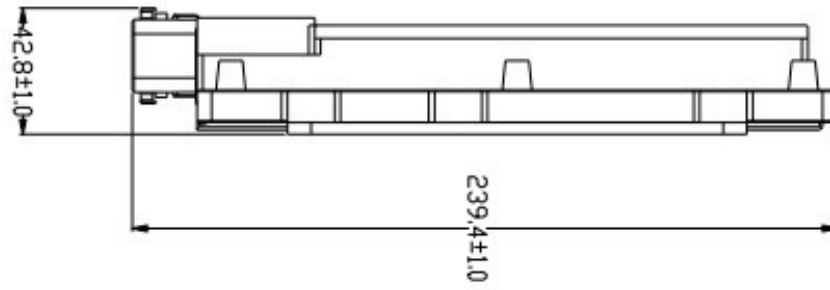

The appearance of the housing is as follows:

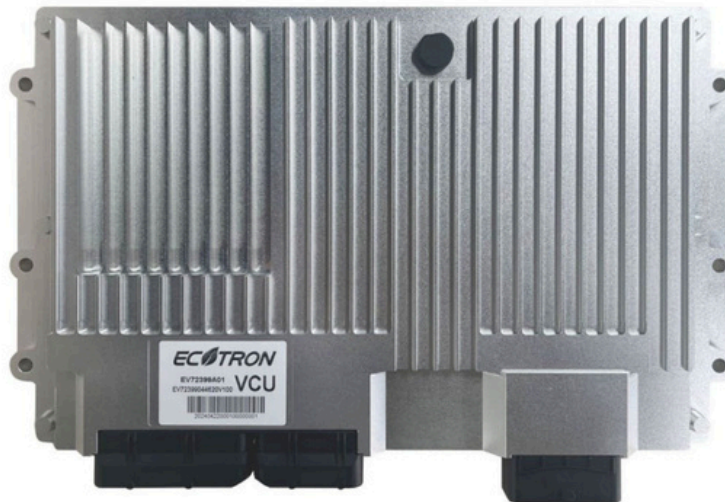

Please use Torx T15 screwdriver to disassemble and assemble the housing.

1.3 Tech Specs

Feature	Detail
Micro Control Core	32-bit SAK-TC399XP-256F300S BD
Maximum Frequency	300MHz
Flash	16MB
SRAM	2.9M
Float Point Capability	Yes

1.4 Recommended Software Tools

Controller Model	SV82399A
Main Chip	Infineon TC399
Integrated Development Environment	HighTec TriCore Tool Chain
EcoCoder Version	EcoCoder v2.9.16 R1 and above
EcoFlash Version	EcoFlash v1.1.7.5 and above
EcoCAL Version	EcoCAL V2.1.8.3 and above

1.5 Power Supply

The SV82399A requires one continuous power supply (PIN10 of 121 pins) to power up the ZCU controlled by a key switch (PIN6 of 64 pins).

A5A fuse in series with PIN10 is recommended for SV82399A power supply.

1.6 Description of Bootloader

The SV82399A bootloader supports UDS protocol by factory default.

Chapter 2 Technical Performance

2.1 Electrical Characteristics

Item	Design Specifications
Operating Voltage	DC 12V/24V (9~32V)
Operating Temperature	-40°C~105°C
Working Humidity	0~95%, no condensation
Storage Temperature	-40°C~85°C
Quiescent Current	<3mA
Rated Power Consumption	<10W
Protection Level	IP67
Weight	≤2700g
Controller Size	365×239×43mm
Material	Die-cast Aluminum
Housing	Equipped with waterproof and breathable valve, good heat dissipation

2.2 Electrical Performance Standard

Item	Test Standard
Overvoltage (high temperature)	ISO 16750-2
Trip voltage	ISO 16750-2
AC voltage superposition test	ISO 16750-2
Supply voltage drops and rises slowly	ISO 16750-2
Instantaneous drop in supply voltage	ISO 16750-2
Reset performance against voltage dips	ISO 16750-2
Start features	ISO 16750-2
Reverse voltage	ISO 16750-2
Reference ground and supply offset	ISO 16750-2
Open circuit experiment-single channel open circuit	ISO 16750-2
Open circuit experiment-multi-channel open circuit	ISO 16750-2
Short circuit protection	ISO 16750-2
Withstand voltage	ISO 16750-2
Insulation resistance	ISO 16750-2

2.3 Environmental Standards

Item	Test Standard
Waterproof (IP67)	IEC/EN 60529
Dustproof (IP67)	ISO 20653
Salt Spray Leakage Function and Corrosion Test	ISO 16750-4
Mechanical Shock Test	ISO 16750-3
Vibration Test	ISO 16750-3
Drop Test	ISO 16750-3
Temperature Shock	ISO 16750-4
Electrical Operation at Circulating Ambient Temperature	ISO 16750-4
High and Low Temperature Operation Experiment	ISO 16750-4
High and Low Temperature Experiment	ISO 16750-4
Temperature and Humidity Cycle	IEC 60068-2-30
Constant Temperature and Humidity	ISO 16750-4

2.4 EMC Test Standard

Item	Test Standard
Voltage Transient Emissions Test	ISO7637-2
Conducted Emission (CE-V)	CISPR25
Conducted Emission (CE-C)	CISPR25
Radiation Emission (RE-ALSE)	CISPR25
Radiation Immunity Experiment (I/O)-ICC	ISO7637-3
Radiation Immunity Experiment BCI-Substitution Method	ISO11452-4
Radiation Immunity Experiment (RI)	ISO11452-2
Low Frequency Magnetic Field Immunity	ISO11452-8
ESD	GMW3097

Chapter 3 Installation Requirements

It is recommended to install the ZCU in the cockpit. If the OEM wants to assemble the ZCU in another location, the corresponding installation location should be evaluated by engineers from both Ecotron and the OEM.

The precautions for ZCU installation are as follows:

1. The ZCU and wiring harness installation should be firm and reliable, and there should be no looseness. Avoid supporting the wiring harness by ZCU. At the same time, the arrangement of the ZCU wiring harness should prevent and protect all wires in the wiring harness from damage due to wear and to overheat.
2. Try to avoid installing it in places where dust is easy to gather. A large amount of dust accumulation will affect the reliability of ZCU work.
3. ZCU should keep away from the location where the temperature of the housing itself may exceed 85°C. At the same time, it is necessary to prevent the surrounding parts from releasing heat to the ZCU.
4. Avoid installing the ZCU in locations where oil, moisture, and water droplets are likely to splash on it.
5. Avoid the possibility of additional mechanical shock and external impact due to the installation position and fixing method of the ZCU and avoid installing the ZCU at the resonance point of the car body.
6. Avoid installing the ZCU where it may come into contact with the battery or other parts that are prone to seepage of acid and alkaline solutions and near the ZCU power terminal.
7. ZCU should be installed in the horizontal and vertical position according to the connector downwards and maintain a certain angle to prevent water from entering the connector. In the horizontal direction, the recommended installation angle is -170° to -10° , as shown in Figure 13 below. In the vertical direction, the recommended installation angle is $-170^\circ \sim -10^\circ$, as shown in Figure 14 below.

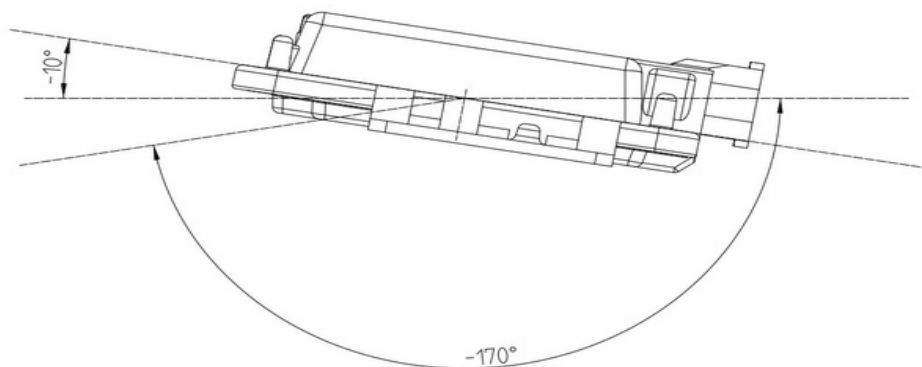
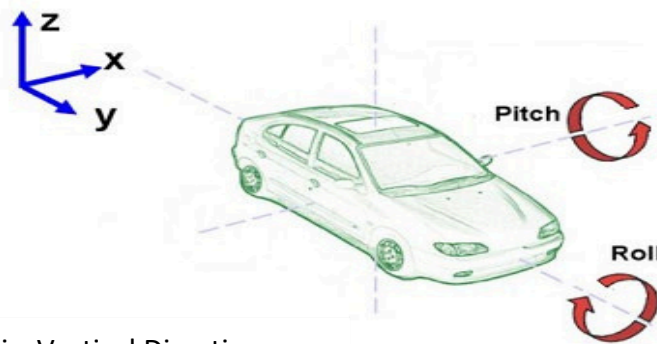

Figure 13 Horizontal Installation Angle



Z Axis: Vertical Direction
X Y Axes: Horizontal Direction

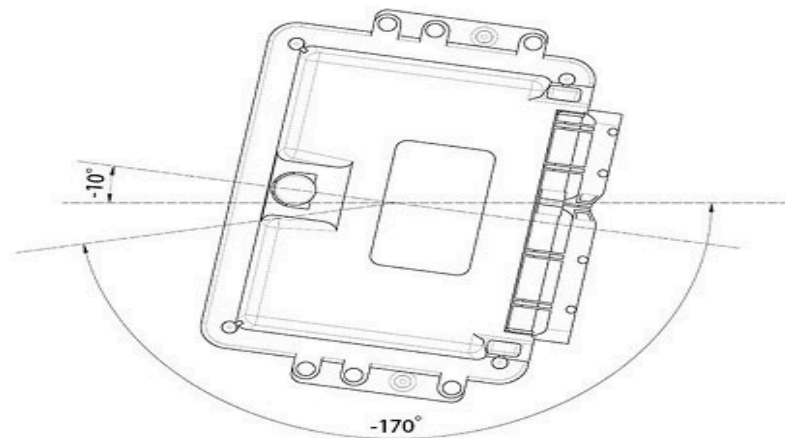

Figure 14 Vertical Installation Angle

Ecotron recommends using the six mounting holes on the ZCU for installation. It is recommended to use metal materials such as aluminum alloy for the mounting bracket. The housing should have a reliable electrical connection with the vehicle body through the bracket. If other materials are used, the customer must ensure that they can meet the requirements of ZCU for vibration, heat dissipation, temperature, EMC, etc. If there is any deviation, it needs to be confirmed with Ecotron.

The ZCU system connects to the ground through the vehicle's body. The specific requirement is to directly connect the ground wire in the wiring harness to the vehicle's body and ensure reliable electrical connections.

Suggestions for mechanical installation: (users can change it according to the vehicle)

1. Suggested specifications for installing fixing screws: M6 nuts, screws M6*25 or so.
2. Recommended torque for installation and tightening: 7 N-m.
3. The size and parameters of the anti-seismic pads that need to be installed are recommended: inner diameter 6mm, outer diameter 20mm, thickness 15mm.