



EATHA20

Datasheet

V1.0.1

ECOTRON CORPORATION

www.ecotron.ai

Revision History

Revision Date	Version	Description
2025.12	V1.0.0	Initial Release

Contact us:

Web: <http://www.ecotron.ai>

Email: info@ecotron.ai

support@ecotron.ai

Address: 2942 Columbia Street

Torrance, CA, 90503

United States

Tel: +1 562-758-3039

+1 562-713-1105

Table of Contents

1. OVERVIEW	5
2. INTERFACE CONFIGURATION	6
3. MECHANICAL STRUCTURE	8
3.1 DIMENSIONAL DRAWINGS	9
3.2 CONNECTORS.....	9
4. QUICK START	11
4.1 PREPARE IN ADVANCE	12
4.2 THE BASICS	12
4.3 USE THE DEVICE	12
5. HARDWARE DESCRIPTION	13
5.1 SPECIFICATIONS.....	14
5.2 DEVICE PORTS.....	14
5.2.1 <i>Port distribution</i>	14
5.2.2 <i>Port definitions</i>	17
5.3 MAIN SYSTEM CHIP.....	25
5.4 CIRCUIT STRUCTURE DIAGRAM.....	27
5.5 CIRCUIT DESCRIPTION.....	27
5.5.1 <i>Analog Signal Input</i>	28
5.5.2 <i>Digital Signal Input</i>	28
6. BASE SOFTWARE	29
7. APPLICATION SCENARIO	32
8. DEVELOPMENT TOOLS	33
8.1 ECOCODER.....	34
8.2 ECOCAL.....	36
8.3 ECOFLASH	37
9. INSTALLATION GUIDELINES	38

1. Overview

EATHA20 is designed with NVIDIA Jetson Thor + Infineon TC4D9 architecture, with a computing power of up to 2070TFLOPS, and is suitable for L3~L5 unmanned driving applications, which can integrate computing-intensive sensor data processing, fusion and control strategy development into a control unit. It can be used in unmanned logistics distribution, unmanned sanitation, unmanned mining vehicles, unmanned buses, intelligent construction machinery, and other applications with large computing power requirements.



2. Interface Configuration

Interface type	Quantity	Function	Internal Chip	Connector
Camera Interface	16	GMSL/GMSL2	SOC	4*4 cavity connector
Video Output Interface	2	FPDLINK	SOC	HSD connectors
Gigabit Automotive Ethernet	8	1000Base-T1	Switch	2*4 cavity connector
Standard Gigabit Ethernet	4	100BASE-T/1000BASE-T Standard	Switch	4* Aviation plug
10 Gigabit Optical Port	1	10G	SOC	SFP optical port
HDMI	1		SOC	
USB	1	One USB Host supports USB 2.0, USB 3.0, and USB 3.1.	SOC	
M.2 KEY M	2	System disk/extended storage	SOC	Inside
GNSS+IMU	1	Optional	SOC	
WIFI	1	Optional	SOC	
4G	1	Optional	SOC	
5G	1	Optional	SOC	
Audio interface	2	Optional	SOC	
CANFD	4		SOC	121PIN-CMC
RS232	3	1 port used for debug	SOC	
PPS_IN	1	Support 5V-16V	SOC	
PPM	1		SOC	
CAN	1		GNSS	
RS232	1		GNSS	
CANFD	8	2 channels with specific frame wake-up	MCU	
USS	12		MCU	
KEYON	3	1 for SOC and 2 for MCU	MCU	
Digital acquisition	6	Default configuration, 4-way high effective 2 ways low effective	MCU	

Analog acquisition	6		MCU	
Low-side drive	8	8 @250mA	MCU	
High-side drive	4	4 @1A	MCU	
5V sensor power supply	2	The maximum current is 100mA	MCU	
Positive power supply	6			
Ground power supply	7			
Signal ground	5			

3. Mechanical Structure

3.1 Dimensional drawings

The outside of the controller housing has no special treatment or plating, and there are no sharp burrs or sharp edges.

3.2 Connectors

The connector products used in the EATHA20 are qualified products that meet the safety level of automobiles, and the connector models are as follows:

Serial number	Connectors	Name	Category	Suppliers	Link
1	121P	PCB headers	1746979-1	TE	--
2		81P sheath	1473244-1	TE	http://www.digikey.com/products/en?keywords=1473244-1
3		40P sheath	1473252-1	TE	http://www.digikey.com/products/en?keywords=1473252-1
4		Large terminals	964273-2	TE	http://www.digikey.com/products/en?keywords=964273-2%20
5		Small terminals	968220-1	TE	http://www.digikey.com/products/en?keywords=968220-1
6		81P Back Cover	1473247-1	TE	http://www.digikey.com/products/en?keywords=1473247-1
7		40P back cover	1473255-1	TE	http://www.digikey.com/products/en?keywords=1473255-1
8		81P snap	368382-1	TE	http://www.digikey.com/products/en?keywords=368382-1
9		40P snap	368388-1	TE	http://www.digikey.com/products/en?keywords=368388-1
10	4-cavity	Plate end	2404815-1	TE	

11	waterproof connector	Line end	<u>2-2354439-1</u>	TE	
12	4 cavity waterproof connectors	Plate end	E3SW4A-BMR131-S00	Amphenol	
13		Line end	E3WS4Z-WFS101-T02	Amphenol	
14	Aviation plug	Plate end	EEG.1K.308.CLN	ZRJM	
15		Line end	FGG.1K.308.CLA C	ZRJM	
16		Plate end	M8-F1-S8	DAOSM	
17		Line end	M8-D-P8	DAOSM	
18	Antenna interface	Waterproof antenna interface	SMA-KKY-22.2MM	YINSAIGE	

4. Quick start

4.1 Prepare in advance

Before using this device, please prepare the following items:

- Stable power supply, 12V DC/ 20A min or 24V DC /10A min
- USB to RS-232
- Laptop

4.2 The Basics

If you are a Linux beginner, it would be helpful to learn some quick tutorials on Linux command-line tools first. Please review the following tutorial: [Linux tutorial](#).

4.3 Use the device

1. Connection

Connect the positive and negative poles of the device (BATT A as the main power supply, BATT B as the backup power supply) to the DC power supply, and connect the serial port 3 of the device to the computer through the USB to RS-232 cable to ensure that the computer can use the serial port device normally.

2. Configuration

Configure serial port: Baud rate 115200, 8 data bits, no parity, 1 stop bit.

Use MobaXterm or Putty for Windows, Minicom for Linux, etc., to open the serial port

3. Launch

Turn on the KeyOn switch of the device, start the power of the device, the device first starts U-

Boot, then runs the Linux system, you can see the normal boot of the system through the serial terminal window, and then you can log in with the default username: **nvidia**, password: **nvidia**

5. Hardware Description

The hardware circuit of the computing platform is designed according to the application needs of the autonomous driving system. The electrical parameters meet the requirements of the vehicle specification level and have a variety of data transmission interfaces to meet the needs of multi-sensor fusion of the autonomous driving system.

5.1 Specifications

Project	Design Metrics
Operating voltage	DC 9~32V
Running space	128GB
Storage space	Refer to the size of the optional SSD
Operating temperature	-25~70°C
Operating humidity	0~95%, non-condensing
Storage temperature	-40~85°C
Waterproof	IP5X
Heat dissipation	Wind/water cooling for heat dissipation

5.2 Device ports

5.2.1 Port distribution

The distribution of input and output ports of the computing platform is shown in the figure below, which is a positive view.



Figure 1 Top view of the controller

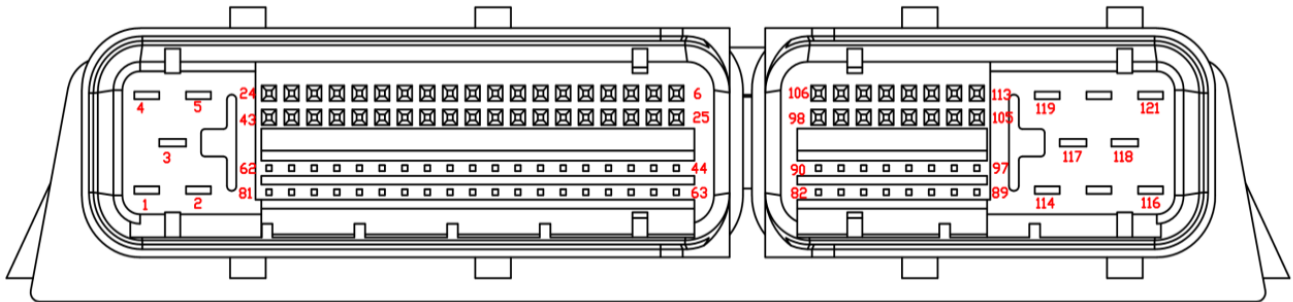

Figure 2 121P connector

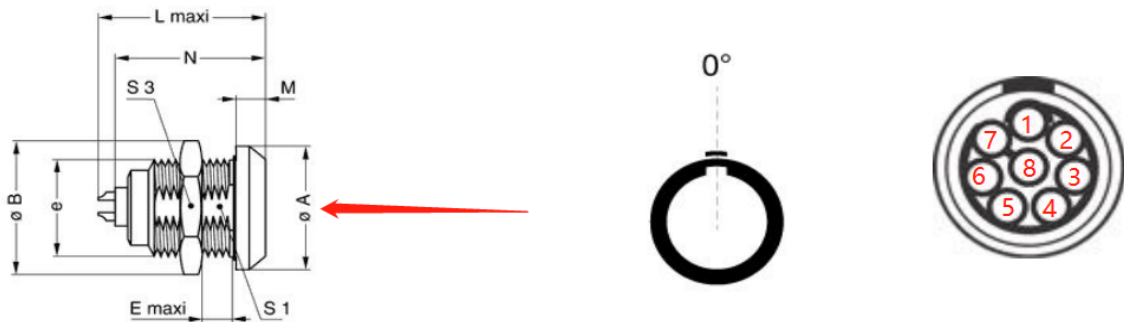

Figure 3 Ordinary Ethernet connector

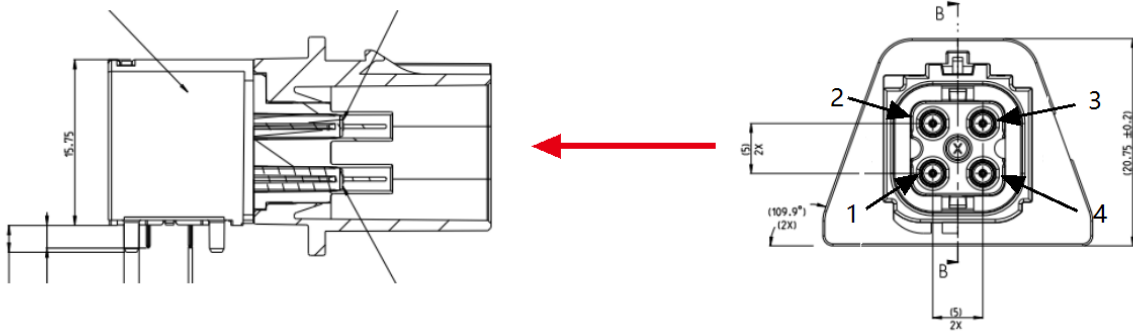
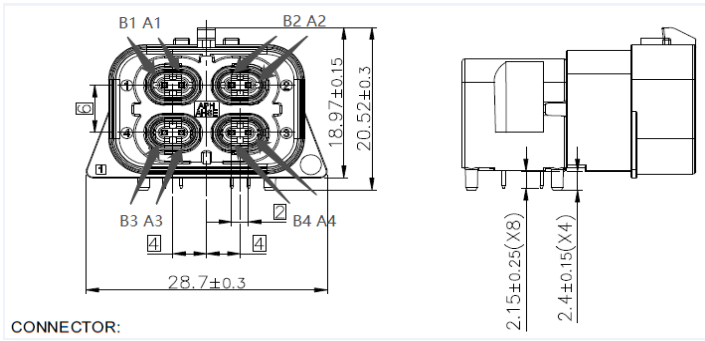

Figure 4 Camera connector



CONNECTOR:



Figure 5 Automotive Ethernet connector

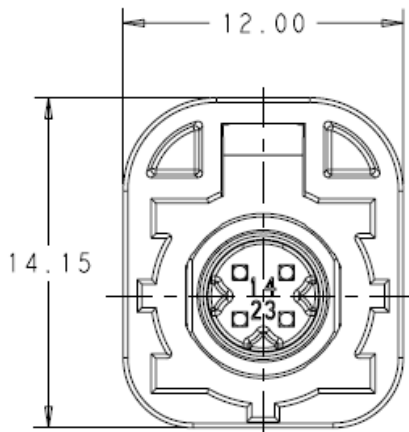

Figure 6 Antenna connector

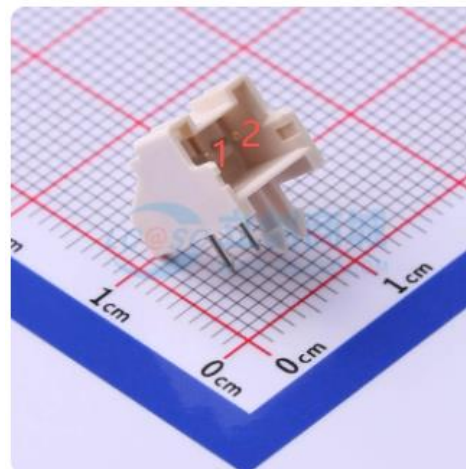

Fig.7 HSD video output connector

Fig.8 Audio A2B connector

5.2.2 Port definitions

The function definitions of the input and output ports of the computing platform are shown in the table below:

Signal name	PIN	Interface description	Note:
E3SW Automotive Ethernet			
P1_MDI_P	E3SW_B1	Automotive Ethernet interface1	1000Base-T1
P1_MDI_N	E3SW_A1		
P2_MDI_P	E3SW_B2	Automotive Ethernet interface2	1000Base-T1
P2_MDI_N	E3SW_A2		
P3_MDI_P	E3SW_B3	Automotive Ethernet interface3	1000Base-T1
P3_MDI_N	E3SW_A3		
P4_MDI_P	E3SW_B4	Automotive Ethernet interface4	1000Base-T1
P4_MDI_N	E3SW_A4		
P5_MDI_P	E3SW_B5	Automotive Ethernet interface5	1000Base-T1
P5_MDI_N	E3SW_A5		
P6_MDI_P	E3SW_B6	Automotive Ethernet interface6	1000Base-T1
P6_MDI_N	E3SW_A6		
P7_MDI_P	E3SW_B7	Automotive Ethernet interface7	1000Base-T1
P7_MDI_N	E3SW_A7		
P8_MDI_P	E3SW_B8	Automotive Ethernet interface8	1000Base-T1
P8_MDI_N	E3SW_A8		
EEG Ordinary Ethernet			
NPort9_BI_DD+	EEG1-1	Standard Ethernet 1	100BASE-TX/1000BASE-T
NPort9_BI_DD-	EEG1-2		
NPort9_BI_DC+	EEG1-3		
NPort9_BI_DC-	EEG1-4		
NPort9_BI_DB+	EEG1-5		
NPort9_BI_DB-	EEG1-6		
NPort9_BI_DA+	EEG1-7		
NPort9_BI_DA-	EEG1-8		
NPort10_BI_DD+	EEG1-1	Standard Ethernet 2	100BASE-TX/1000BASE-T
NPort10_BI_DD-	EEG1-2		
NPort10_BI_DC+	EEG1-3		

NPort10_BI_DC-	EEG1-4		
NPort10_BI_DB+	EEG1-5		
NPort10_BI_DB-	EEG1-6		
NPort10_BI_DA+	EEG1-7		
NPort10_BI_DA-	EEG1-8		
NPort11_BI_DD+	EEG1-1	Standard Ethernet 3	100BASE-TX/1000BASE-T
NPort11_BI_DD-	EEG1-2		
NPort11_BI_DC+	EEG1-3		
NPort11_BI_DC-	EEG1-4		
NPort11_BI_DB+	EEG1-5		
NPort11_BI_DB-	EEG1-6		
NPort11_BI_DA+	EEG1-7		
NPort11_BI_DA-	EEG1-8		
NPort12_BI_DD+	EEG1-1	Standard Ethernet 4	100BASE-TX/1000BASE-T
NPort12_BI_DD-	EEG1-2		
NPort12_BI_DC+	EEG1-3		
NPort12_BI_DC-	EEG1-4		
NPort12_BI_DB+	EEG1-5		
NPort12_BI_DB-	EEG1-6		
NPort12_BI_DA+	EEG1-7		
NPort12_BI_DA-	EEG1-8		
SFP optical port	SFP optical port	SFP optical port	10G
Camera interface			
Camera-1	2404815-4	GMSL/GSML2 serial camera interface 1	
Camera-2	2404815-3	GMSL/GSML2 serial camera interface 2	
Camera-3	2404815-2	GMSL/GSML2 serial camera interface 3	
Camera-4	2404815-1	GMSL/GSML2 serial camera interface 4	
Camera-5	2404815-4	GMSL/GSML2 serial camera interface 5	
Camera-6	2404815-3	GMSL/GSML2 serial camera interface 6	

Camera-7	2404815-2	GMSL/GSML2 serial camera interface 7	
Camera-8	2404815-1	GMSL/GSML2 serial camera interface 8	
Camera-9	2404815-4	GMSL/GSML2 serial camera interface 9	
Camera-10	2404815-3	GMSL/GSML2 serial camera interface 10	
Camera-11	2404815-2	GMSL/GSML2 serial camera interface 11	
Camera-12	2404815-1	GMSL/GSML2 serial camera interface 12	
Camera-13	2404815-4	GMSL/GSML2 serial camera interface 13	
Camera-14	2404815-3	GMSL/GSML2 serial camera interface 14	
Camera-15	2404815-2	GMSL/GSML2 serial camera interface 15	
Camera-16	2404815-1	GMSL/GSML2 serial camera interface 16	
Display interface			
HDMI	HDMI	HDMI display interface	
USB port			
USB Host	USB	USB interface	
Video output interface			
VIDEO-0+	HSD-4	FPDLINK IV video output interface	
VIDEO-0-	HSD-2	FPDLINK IV video output interface	
VIDEO-1+	HSD-1	FPDLINK IV video output interface	
VIDEO-1-	HSD-3	FPDLINK IV video output interface	
Audio interface			
Audio	Audio	Audio interface	
Audio	A2B	Audio A2B interface	
Antenna interface			
GNSS	GNSS	GNSS positioning module antenna interface	
WIFI1	WIFI1	WIFI module antenna interface 1	
WIFI2	WIFI2	WIFI module antenna interface 2	
4G/5G1	4G/5G1	4G module antenna or 5G module antenna interface 1	

5G2	5G2	5G module antenna interface 2	
5G3	5G3	5G module antenna interface 3	
5G4	5G4	5G module antenna interface 4	
SIM card interface			
YES	YES	4G/5G SIM card interface	
Power Ground Part			
BATT	121P-1	BATTB power supply positive terminal	BATTB is the main power supply BATTB is a backup power supply
	121P-3		
	121P-115		
	121P-116	BATTB power supply positive terminal	
	121P-118		
	121P-121		
Power Ground Part			
PGND	121P-2	Power supply negative terminal	
	121P-4		
	121P-5		
	121P-114		
	121P-117		
	121P-119		
	121P-120		
Signal ground part			
GND	121P-57	Signal Ground	
	121P-59		
	121P-65		
	121P-82		
	121P-87		
5V sensor power output part			
5V-1	121P-83	5V-1 sensor power output	The maximum current is 100mA
5V-2	121P-86	5V-2 sensor power output	The maximum current is 100mA
Power-up part			
KEYON39	121P-39	KEYON39	High efficiency, control TC4D9 power-up High level triggering
KEYON44	121P-44	KEYON44	High efficiency, control Thor power-up High level triggering

KEYON56	121P-56	KEYON56	High efficiency, control TC4D9 power-up Rising edge trigger
Simulate the input section			
FW01	121P-42	Analog signal input 0~5V (voltage type).	12-bit precision
FW02	121P-60	Analog signal input 0~5V (voltage type).	12-bit precision
FW03	121P-43	Analog Signal Input (Resistive Type)	12-bit precision
FW04	121P-24	Analog signal input (resistive type).	12-bit precision
FW13	121P-62	Analog signal input 0~36V (voltage type).	12-bit precision
FW14	121P-40	Analog signal input 0~36V (voltage type).	12-bit precision
Number Input Section			
DI01	121P-20	Digital signal input 0~BATT	High effectiveness
DI02	121P-58	Digital signal input 0~BATT	High effectiveness
DI03	121P-77	Digital signal input 0~BATT	Low effectiveness
DI04	121P-38	Digital signal input 0~BATT	Low effectiveness
DI21	121P-74	Digital signal input 0~BATT	High effectiveness
DI22	121P-16	Digital signal input 0~BATT	High effectiveness
Output signal section			
HSO01	121P-88	Rated 0.5A, max. 1A	
HSO02	121P-89	Rated 0.5A, max. 1A	
HSO03	121P-97	Rated at 1A, 1.5A max	
HSO04	121P-96	Rated at 1A, 1.5A max	
LSO01	121P-101	Rated at 250mA	
LSO02	121P-94	Rated at 250mA	
LSO03	121P-90	Rated at 250mA	
LSO04	121P-92	Rated at 250mA	
LSO05	121P-110	Rated at 250mA	
LSO06	121P-103	Rated at 250mA	
LSO07	121P-109	Rated at 250mA	
LSO08	121P-107	Rated at 250mA	
Serial communication interface part			
CAN_A_H	121P-27	No 120 Ω terminal resistance	

CAN_A_L	121P-28		Support CANFD, wake-up to specific frames, Corresponding to CANA in EcoCoder
CAN_B_H	121P-9	No 120 Ω terminal resistance	Support CANFD, wake-up to specific frames, Corresponding to CANB in EcoCoder
CAN_B_L	121P-10		
CAN_C_H	121P-31	Contains 120 Ω terminal resistors	Support CANFD, Corresponding to CANC in EcoCoder
CAN_C_L	121P-32		
CAN_D_H	121P-11	Contains 120 Ω terminal resistors	Support CANFD, Corresponding to CAND in EcoCoder
CAN_D_L	121P-12		
CAN_E_H	121P-29	Contains 120 Ω terminal resistors	Support CANFD, Corresponding to CANE in EcoCoder
CAN_E_L	121P-30		
CAN_F_H	121P-13	Contains 120 Ω terminal resistors	Support CANFD, Corresponding to CANF in EcoCoder
CAN_F_L	121P-14		
CAN_G_H	121P-18	Contains 120 Ω terminal resistors	Support CANFD, Corresponding to CANG in EcoCoder
CAN_G_L	121P-17		
CAN_H_H	121P-22	Contains 120 Ω terminal resistors	Support CANFD, Corresponding to CANH in EcoCoder
CAN_H_L	121P-21		
S_CAN0_H	121P-47	Contains 120 Ω terminal resistors	Support CANFD, Corresponding to Thor's CAN0
S_CAN0_L	121P-66		
S_CAN1_H	121P-48	Contains 120 Ω terminal resistors	Support CANFD, Corresponding to Thor's CAN1
S_CAN1_L	121P-67		
S_CAN2_H	121P-78	Contains 120 Ω terminal resistors	Support CANFD, Corresponding to Thor's CAN2
S_CAN2_L	121P-79		
S_CAN3_H	121P-80	Contains 120 Ω terminal resistors	Support CANFD, Corresponding to Thor's CAN3
S_CAN3_L	121P-81		
CAN_H_LG69T	121P-33	Contains 120 Ω terminal resistors	Support CAN, Used for GNSS interaction
CAN_L_LG69T	121P-34		
CAN_SHILD-1	121P-46	CAN shielded wire	
CAN_SHILD-2	121P-8	CAN shielded wire	
RS232_1_TXD	121P-52	RS-232 serial port 1	Thor ttyTHS0
RS232_1_RXD	121P-71		
RS232_1_GND	121P-36		
RS232_2_TXD	121P-69	RS-232 serial port 2	Thor ttyTHS4
RS232_2_RXD	121P-50		
RS232_2_GND	121P-45		
RS232_3_TXD	121P-51	RS-232 serial port 3	

RS232_3_RXD	121P-70	Thor ttyTCU0 is used for debugging by default	
RS232_3_GND	121P-63		
RS232_GNSS_TXD	121P-72	RS-232 serial port for GNSS	Used for GNSS interaction
RS232_GNSS_RXD	121P-73		
RS232_GNSS_GND	121P-64		
Ultrasonic radar interface part			
USS1	121P-108	IO interface for radar 1	
USS2	121P-100	IO interface for Radar 2	
USS3	121P-99	IO interface for Radar 3	
USS4	121P-112	IO interface for Radar 4	
USS5	121P-105	IO interface for radar 5	
USS6	121P-113	IO interface for Radar 6	
USS7	121P-106	IO interface for Radar 7	
USS8	121P-98	IO interface for Radar 8	
USS9	121P-91	IO interface for Radar 9	
USS10	121P-102	IO interface for Radar 10	
USS11	121P-111	IO interface of the radar 11	
USS12	121P-104	IO interface for Radar 12	
USS-POWER1	121P-37	VCC interface of the 1st group radar	
USS-POWER2	121P-41	VCC interface of the 2nd group radar	
USS-POWER3	121P-53	VCC interface of the 3rd group radar	
USS-POWER4	121P-54	VCC interface of the 4th group radar	
USS-GND1	121P-84	GND interface of the 1st group radar	
USS-GND2	121P-85	GND interface of the 2nd group radar	
USS-GND3	121P-93	GND interface for group 3 radar	
USS-GND4	121P-95	GND interface of the 4th group radar	
Other parts			
PPS_IN	121P-23	Second pulse synchronized input signal	Thor supports 5V-16V
PPM	121P-76		

5.3 Main System Chip

The Autonomous Driving Processor inside the EATHA20 is NVIDIA's Thor chip, which is designed for embedded intelligent systems, including autonomous driving systems. The computing performances of its different internal processors is listed below:

Feature	Detail
AI	Up to 2070 FP4 TFLOPs 1035 FP8 TFLOPs
CPU Complex	14 CPU clusters One core per cluster Arm Neoverse V3AE (64-bit) symmetric multi-processing (SMP) CPU architecture L1 Cache (I, D) per core: 64KB + 64KB L2 Cache per core: 1MB L3 Cache 16MB shared System Cache SPECint@2017_int_base (one core): 6.6 SPECrate@2017_int_base (all cores): 80
Blackwell GPU	3GPC, 10 TPC, 2560 NVIDIA® CUDA® cores 96 5th GEN Tensor cores MIG Support End-to-end lossless compression Tile Caching OpenGL® 4.6+ OpenGL ES 3.2 Vulkan® 1.2+ CUDA 11.4+
Decode	2x NVDEC @ 1.56 GHz NVDEC is on the same rail as the GPU. Supported Standards: H.265 (HEVC), H.264, VP9, VP8, AV1, MPEG-4, MPEG-2, VC-1 Supported Streams: 4x 8Kp30 (H.265), 10x 4Kp60 (H.265), 22x 4Kp30 (H.265), 46x 1080p60 (H.265), 92x 1080p30 (H.265), 4x 8Kp30 (H.264), 10x 4Kp60 (H.264), 20x 4Kp30 (H.264), 40x 1080p60 (H.264), 82x 1080p30 (H.264)
Encode	2x NVENC @ 1.56 GHz NVENC is on the same rail as the GPU. Supported Standards: H.265 (HEVC), H.264 Supported Streams: 6x 4Kp60 (H.265), 12x 4Kp30 (H.265), 24x 1080p60 (H.265), 50x 1080p30 (H.265), 6x 4Kp60 (H.264), 12x 4Kp30 (H.264), 24x 1080p60

	(H.264), 48x 1080p30 (H.264)
Programmable Vision Accelerator (PVA)	1x NVIDIA PVA 3.0

The microcontroller used inside the EATHA20 is Infineon’s TC4D9 series chip. It features a 6-core TriCore™ architecture running at 500 MHz, with up to 10 MB + 20 MB of RAM protected by ECC (Error Correction Code). It is designed in accordance with the ISO26262 standards and supports the highest safety integrity level, ASIL-D. In combination with the base chip, it enables a hardware-level core safety architecture design. The chip resources are as follows:

Feature	Detail
Micro Control Core	32-bit Infineon TC4D9
Maximum Frequency	500MHz
Flash	20MB
SRAM	10MB
EEPROM	256K
Float Point Capability	Yes
SBC	TLF4D985Q

5.4 Circuit Structure Diagram

The internal Hardware circuit diagram structure of the EATHA20 is shown in the figure below:

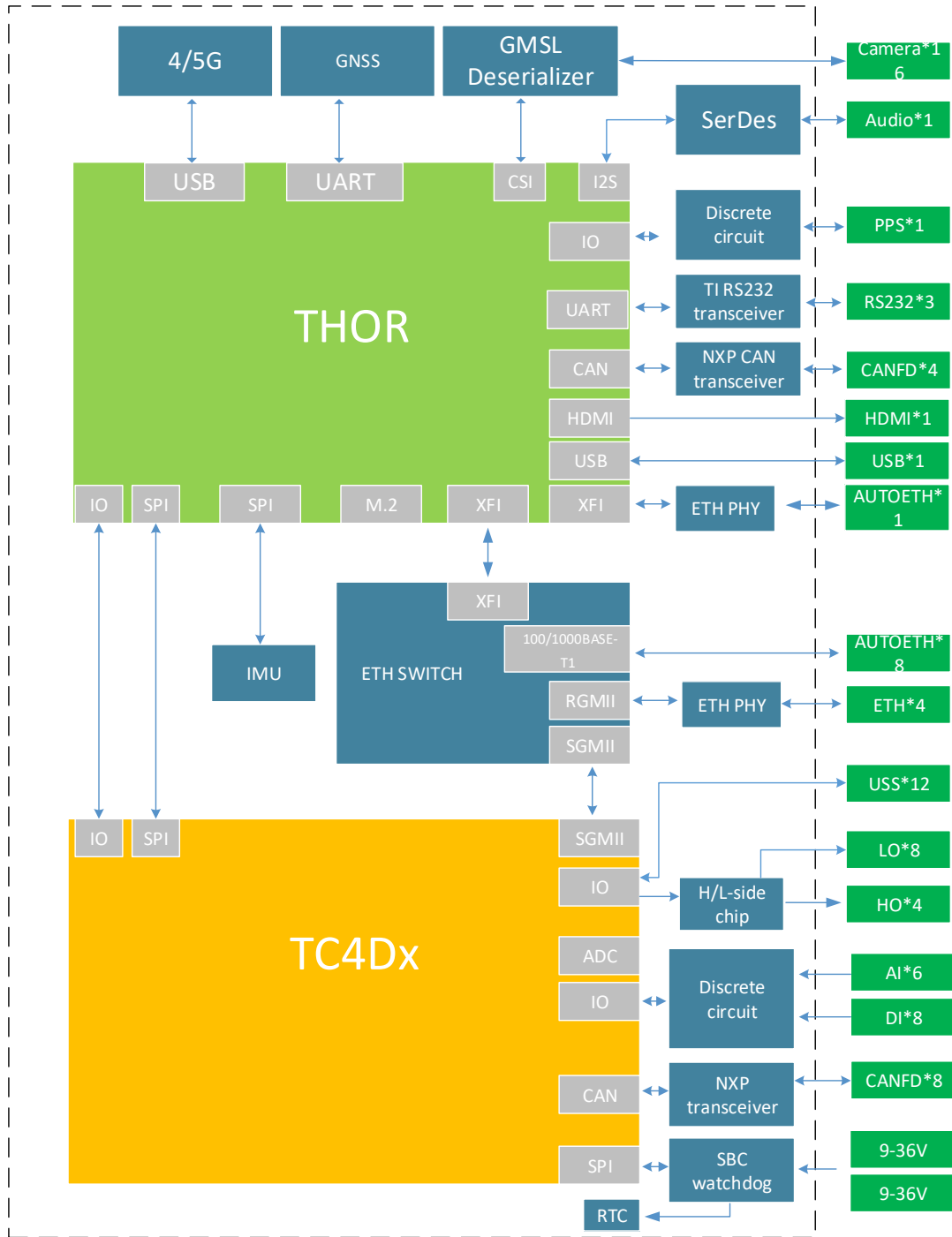

5.5 Circuit Description

5.5.1 Analog Signal Input

The analog input channels share the same circuit diagram. The schematic diagram and circuit details

are shown below:

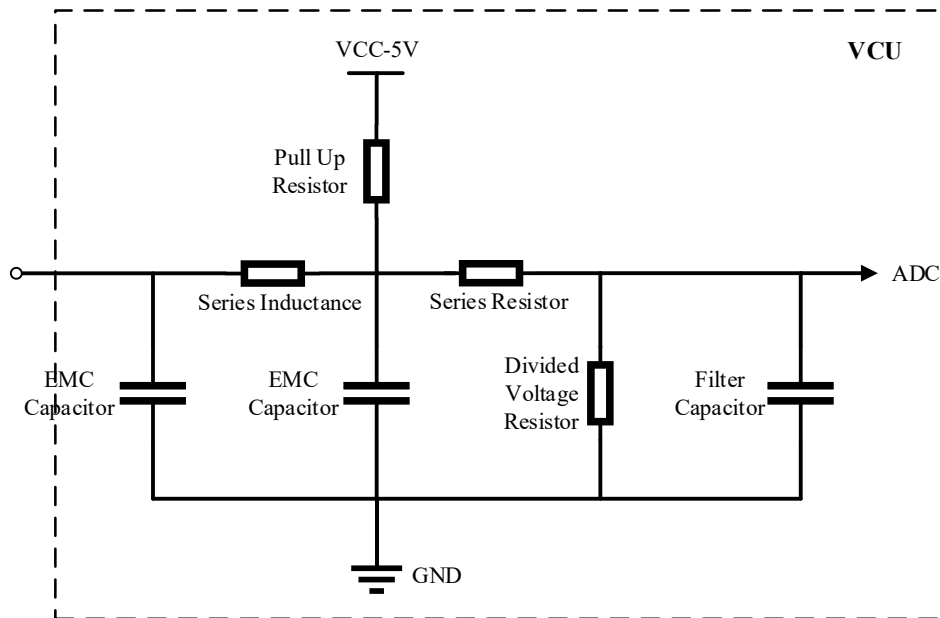

Note: 1.) "--" indicates not populated (not soldered); 2.) UB represents the BATT power supply voltage; 3.) AI28 is not used to measure the BATT voltage signal.

Pin #	AI	EMC Capacitor	Pull Up Resistor	Series Resistor	Divided Voltage Resistor	Filter Capacitor	Input Range		Conditions / Remarks
		(F)	to 5V (Ohm)	(Ohm)	(Ohm)	(F)	Min	Max	
42	AI01	100n	--	22k	--	1n	0V	5V	
60	AI02	100n	--	22k	--	1n	0V	5V	
43	AI03	100n	10k	22k	--	1n	--	--	Resistive Type
24	AI04	100n	10k	22k	--	1n	--	--	Resistive Type
62	AI13	100n	--	22k	3.48k	1n	0V	32V	
40	AI14	100n	--	22k	3.48k	1n	0V	32V	

5.5.2 Digital Signal Input

The digital input channels share the same circuit structure. The schematic diagram and circuit details are shown below:

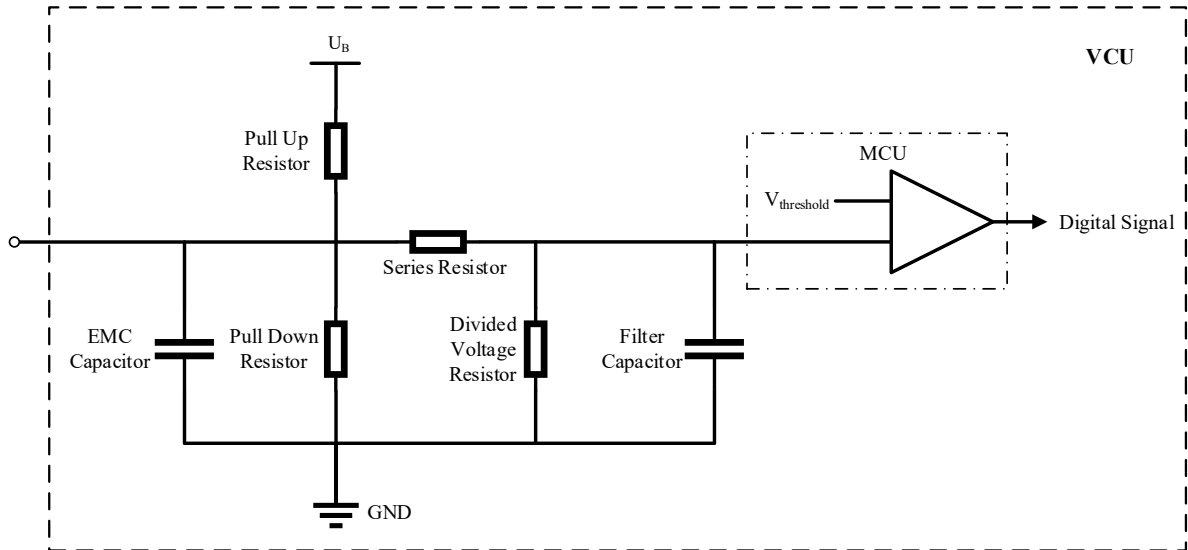

Note: 1.) "--" indicates not populated (not soldered). 2.) U_B represents the BATT power supply voltage. 3.) KEYON and DC_WAKE are used only as hardwired wake-up signals.

Pin #	DI	Pull Up Resistor	Pull Down Resistor	Operation Threshold for Input Signal		Input Range		Conditions/Remarks
		to U_B (Ohm)	(Ohm)	V_{low}	V_{high}	Min	Max	
20	DI01	--	10k	3V	8.5V	0V	U_B	Active High
58	DI02	--	10k	3V	8.5V	0V	U_B	Active High
77	DI03	10k	--	3V	8.5V	0V	U_B	Active Low
38	DI04	10k	--	3V	8.5V	0V	U_B	Active Low
74	DI21	--	10k	3V	8.5V	0V	U_B	Active High

16	DI22	--	10k	3V	8.5V	0V	U _b	Active High
----	------	----	-----	----	------	----	----------------	-------------

6. Base Software

The SoC software system of this computing platform is custom developed for autonomous driving systems. The figure below shows a typical block diagram of an autonomous driving system. The Software system of this computing platform includes components such as the RTOS and the Runtime Framework. The RTOS is the Linux operating system, and the Runtime Framework is the melodic version of ROS (Robot Operating System).

The Linux operating system sits between the underlying hardware and the user, serving as a bridge between the two. Users can input commands through the operating system's user interface. The operating system interprets these commands, drives the hardware devices, and fulfills the user's requests. It provides the following functions: Processing management, Memory management, File system, Networking, Security, User interface, Device drivers, etc.

ROS provides a set of standard operating system services, such as hardware abstraction, low-level device control, implementation of commonly used functionalities, inter-process messaging, and data packet management. ROS is built on a graph-based architecture, enabling processes to run in different nodes to receive, publish and aggregate various types of information (such as sensing, control, status, planning, etc.).

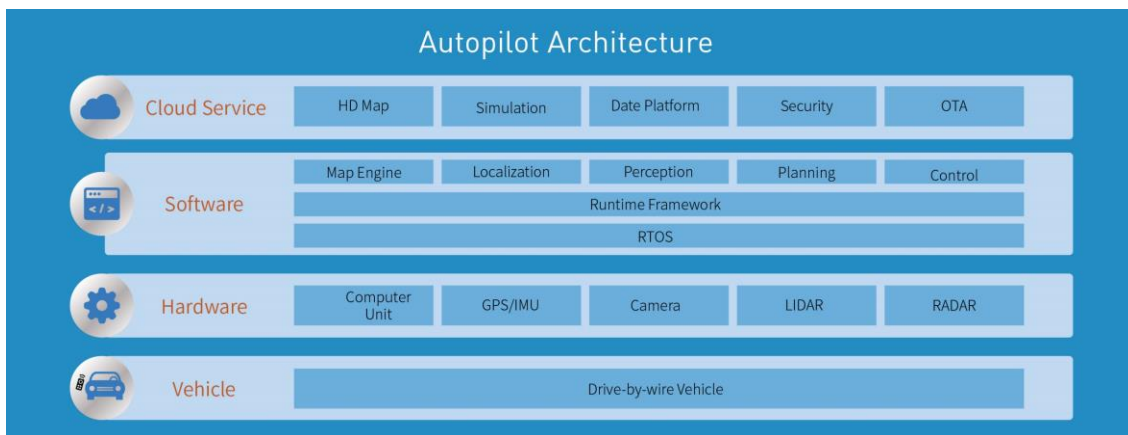

The MCU software architecture within the Thor computing platform is designed in accordance with the AUTOSAR architecture standard. It is divided into the Application Software Layer and the Basic Software Layer. The Basic Software Layer is further divided into the Microcontroller Abstraction Layer,

ECU Abstraction Layer, Service Layer, and Complex Drivers. The Application Software Layer and the Basic Software Layer are integrated and connected through EcoCoder. EcoCoder utilizes Simulink S-functions to encapsulate low-level interfaces into a Simulink module library. Application developers can build application-layer models in Simulink and generate executable program files compatible with the TC4D9 with a single click through Simulink.

The low-level interfaces encapsulated by EcoCoder enable reading the status of digital input and analog signals, controlling high-side and low-side outputs, and supporting DBC file parsing as well as protocols such as CCP and UDS. It also allows the definition of measurement variables, calibration parameters, and NVM variables. Together with the calibration software EcoCAL and the flashing software EcoFlash, it supports the development of MCU application programs.

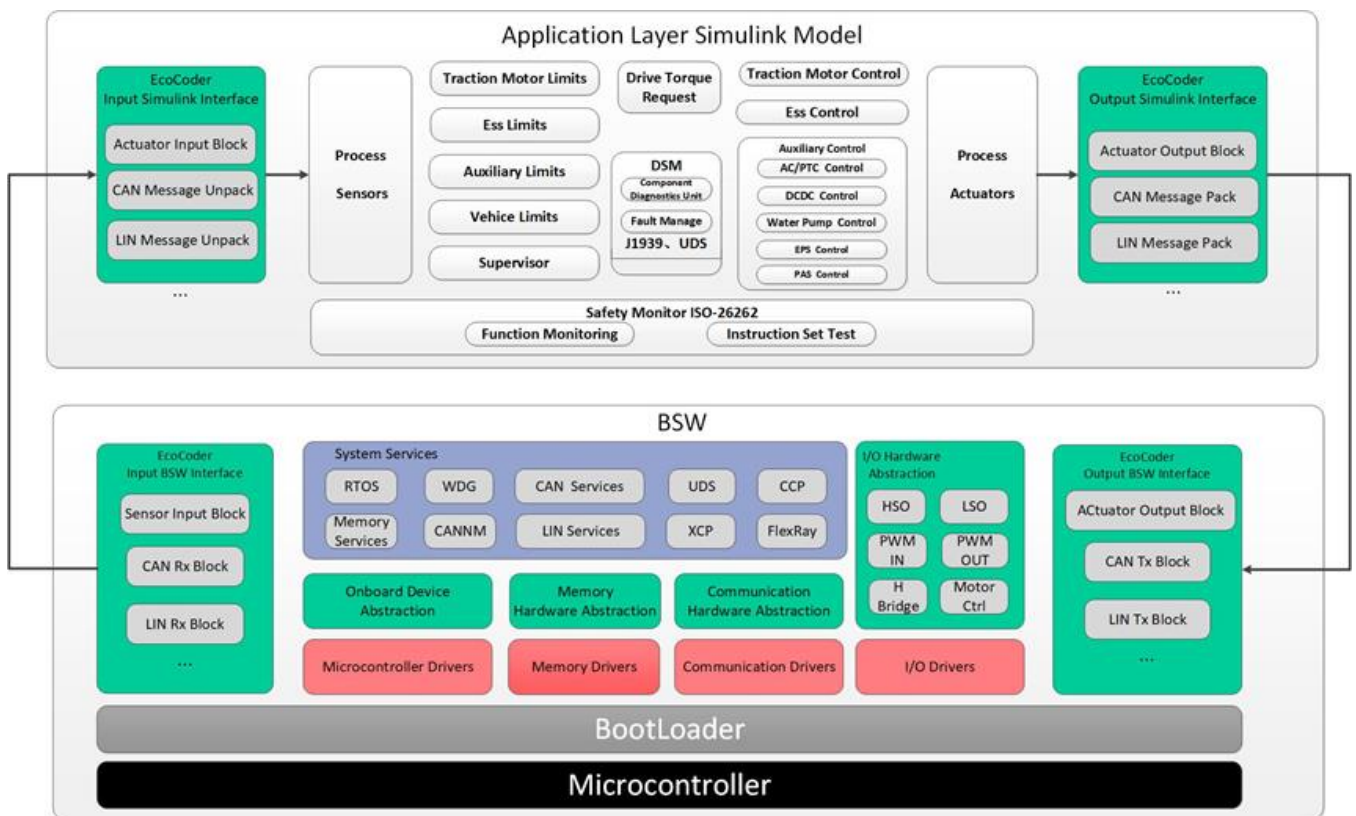

7. Application Scenario

EATHA20 is used in the field of autonomous driving. It uses various sensors to form the hardware platform of an autonomous driving system. A common connection method is shown in the figure below:

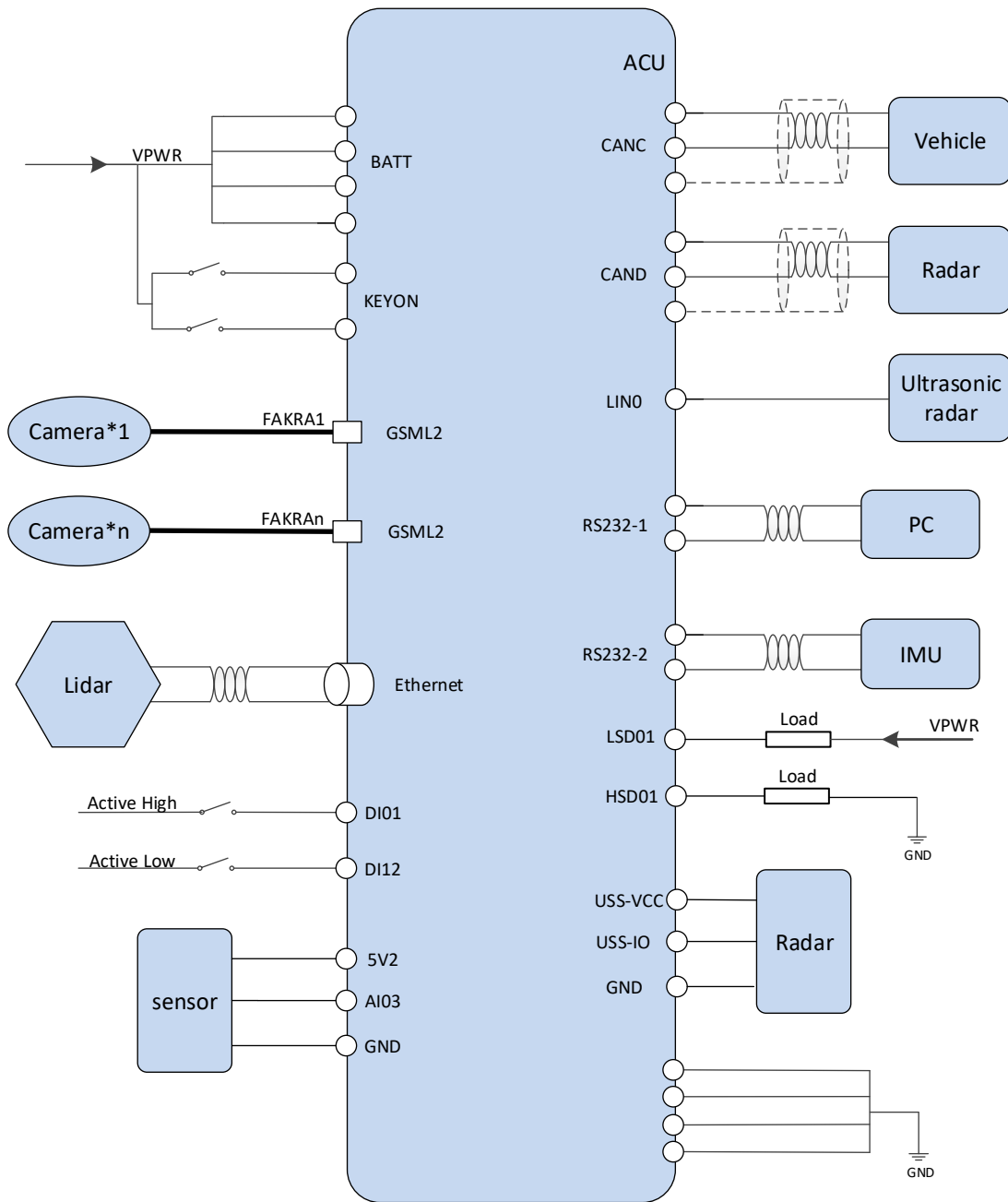

8. Development Tools

The MCU software architecture within the Thor computing platform is designed in accordance with the AUTOSAR architecture standard. It is divided into the Application Software Layer and the Basic Software Layer. The basic Software Layer is further subdivided into Microcontroller Abstraction Layer, ECU Abstraction Layer, Service Layer, and Complex Drivers Layer. The Application Software Layer and the Basic Software Layer are integrated and connected through the EcoCoder. EcoCoder uses Simulink S-functions to encapsulate low-level interfaces into a Simulink module library. Application developers can build application-layer models in Simulink and generate executable program files compatible with the TC4D9 with a single click in Simulink.

8.1 EcoCoder

EcoCoder is an application development tool for control systems that enables users to more conveniently develop embedded application-layer programs within the Simulink environment. It extends Simulink and Real-Time Workshop Embedded Coder by providing the necessary code modules for generation and performs automatic configuration and optimization of the generated code. The basic software library is encapsulated as S-functions, allowing developers to use basic software interfaces in a graphical manner and perform basic parameter configuration. EcoCoder supports one-click generation of executable files and data description files and also provides an A2L address update tool.

Features:

- Users can develop embedded application-layer programs within the Simulink environment.
- Application-layer developers do not need to focus extensively on the microcontroller or hardware platform, allowing them to concentrate on control strategy development and reducing the involvement of cost of low-level software and hardware engineers.
- The basic software library is encapsulated as S-functions, enabling developers to use basic software interfaces graphically and perform parameter configurations, thereby lowering the difficulty for application-layer developers to use low-level software.
- Executable files and data description files can be generated from the application-layer model with a single click, and an A2L address update tool is provided.
- An automated integration approach is adopted, where the code generated from the application-layer model is automatically integrated with the low-level software in the

background. The compiler is invoked automatically via a makefile to generate the executable file, eliminating the need for manual integration between the application and basic software layers and reducing the workload of the software integration engineers.

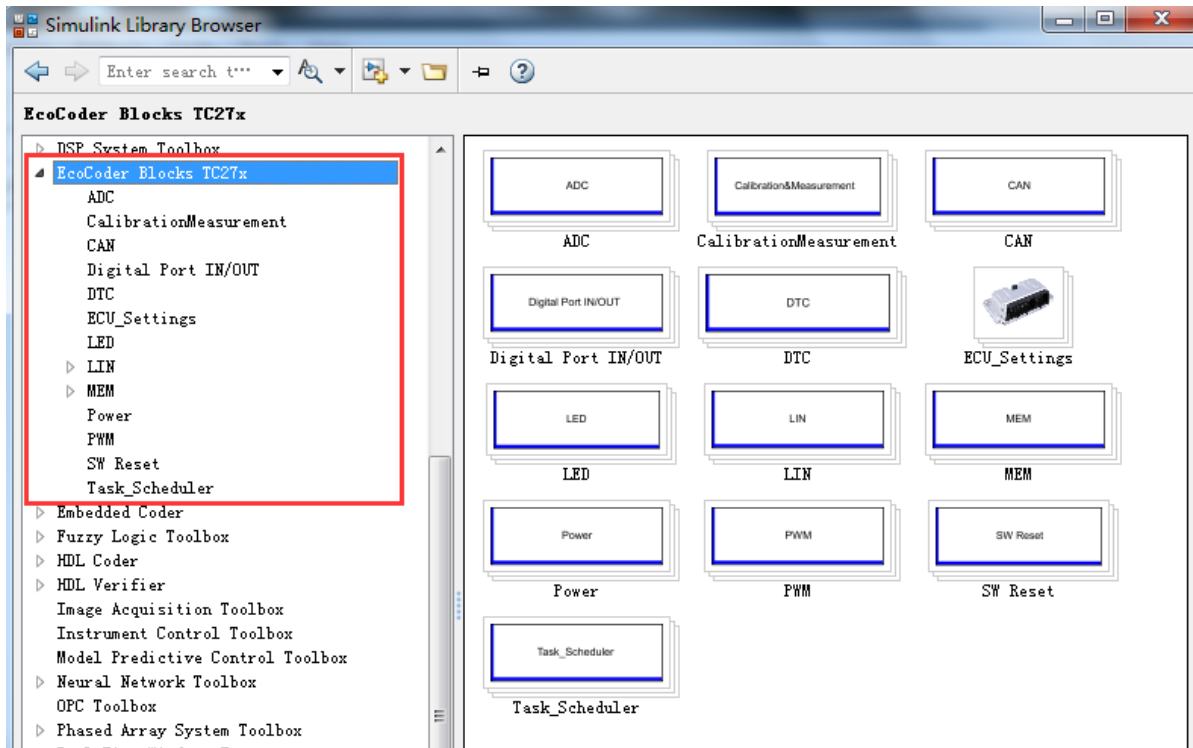

If the model simulation runs successfully, you can press the shortcut “Ctrl + B” or click the icon shown below to generate a flashable file with one click.

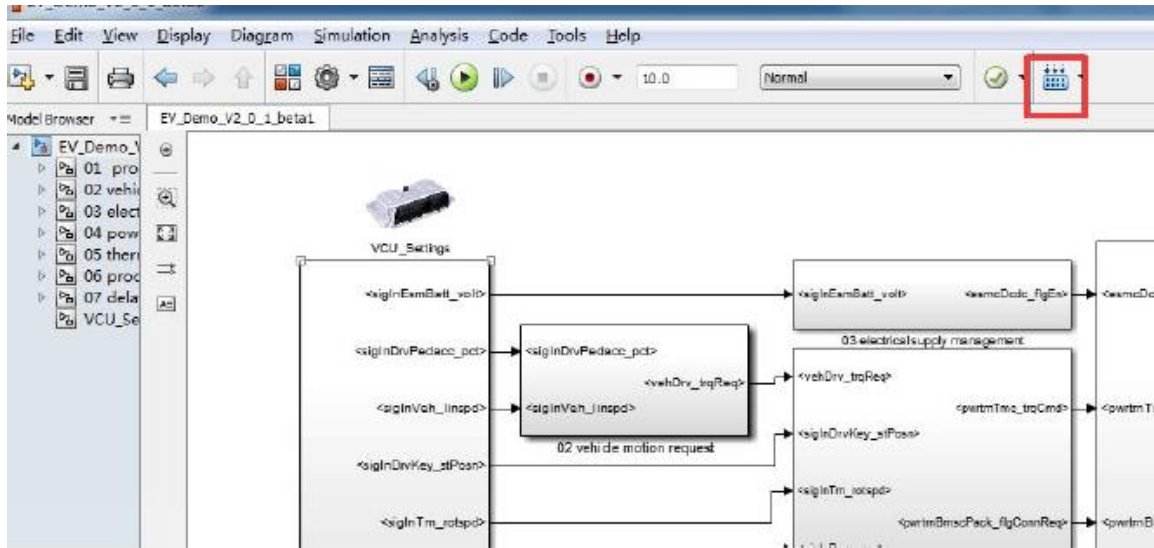

Application developers can use this tool to develop applications for the MCU inside the autonomous driving domain controller. For more details, please refer to the document “EcoCoder User Manual”.

8.2 EcoCAL

EcoCAL is a PC-based calibration software that operates using the CPP protocol. By loading A2L and Hex files, it enables real-time monitoring of measurement variables and online calibration of its calibration parameters. It assists control strategy development engineers in debugging and calibrating application software. For more details, please refer to the document “EcoCoder User Manual”.

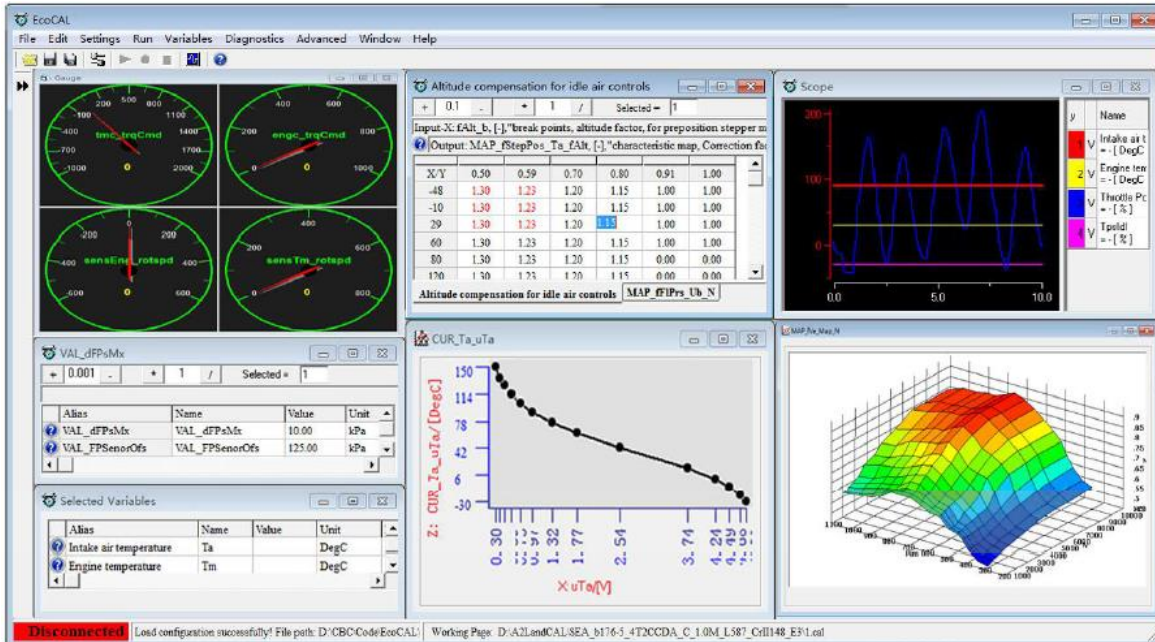

8.3 EcoFlash

EcoFlash is our in-house developed PC software used in conjunction with the BootLoader to perform online flashing of program target files. It uses the CAN communication protocol with CPP/UDS support and can flash target files in .S19, .Mot, or .Hex formats.

9. Installation Guidelines

Ecotron recommends installing the ADCU inside of the user's vehicle cabin. If the OEM prefers to mount the ADCU in a different location, the installation position should be jointly evaluated by Ecotron's engineering team and engineers from the vehicle manufacturers.

ADCU Installation Precautions:

- 1) The ADCU and its wiring harness should be installed securely and reliably, with no looseness. The ADCU should not be used to support the harness. The harness layout must protect all wires from damage caused by abrasion or overheating.
- 2) Avoid installing the ADCU in areas where dust tends to accumulate, as excessive dust can affect its operational reliability.
- 3) The ADCU should be kept away from locations where its casing temperature could exceed the range of -15 to 70°C , and nearby components should not radiate excessive heat towards it. It is recommended to install the ADCU in areas with sufficient airflow to facilitate heat dissipation.

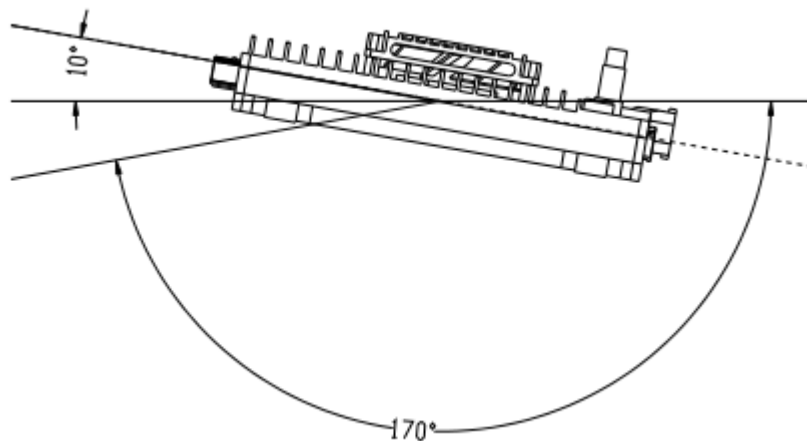

- 4) The ADCU should not be installed in locations prone to oil contamination, moisture, or water splashing.
- 5) The installation position and mounting method should prevent the ADCU from being subjected to additional mechanical vibrations or external impact. Avoid installing the ADCU at vehicle body resonance points.

- 6) Avoid installing the ADCU near areas where it could come into contact with the battery or other locations prone to leakage of acidic or alkaline solutions, as well as places where the ADCU may be exposed to corrosion.
- 7) The ADCU should not be installed near the battery's positive terminal or ignition power wiring terminals.
- 8) When installing the ADCU, the connectors should be angled downward both horizontally and vertically to prevent water from entering through the connectors. For horizontal installation, a range of -170° to -10° is recommended. For vertical installation, a range of -170° to -10° is recommended (See diagram below).

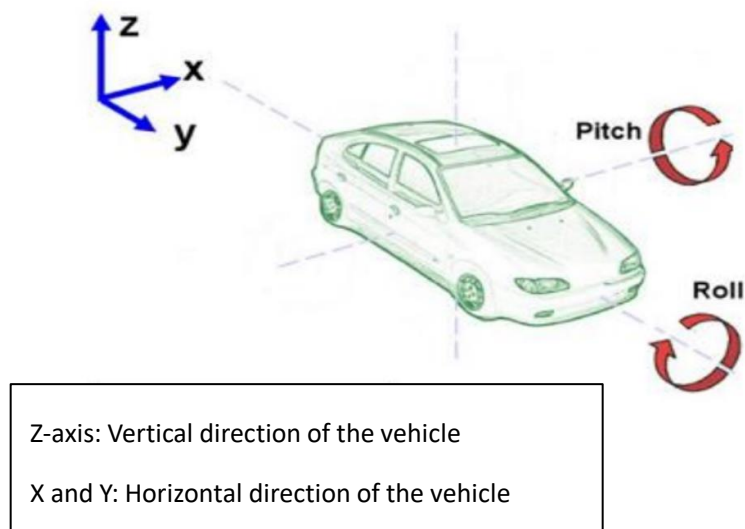

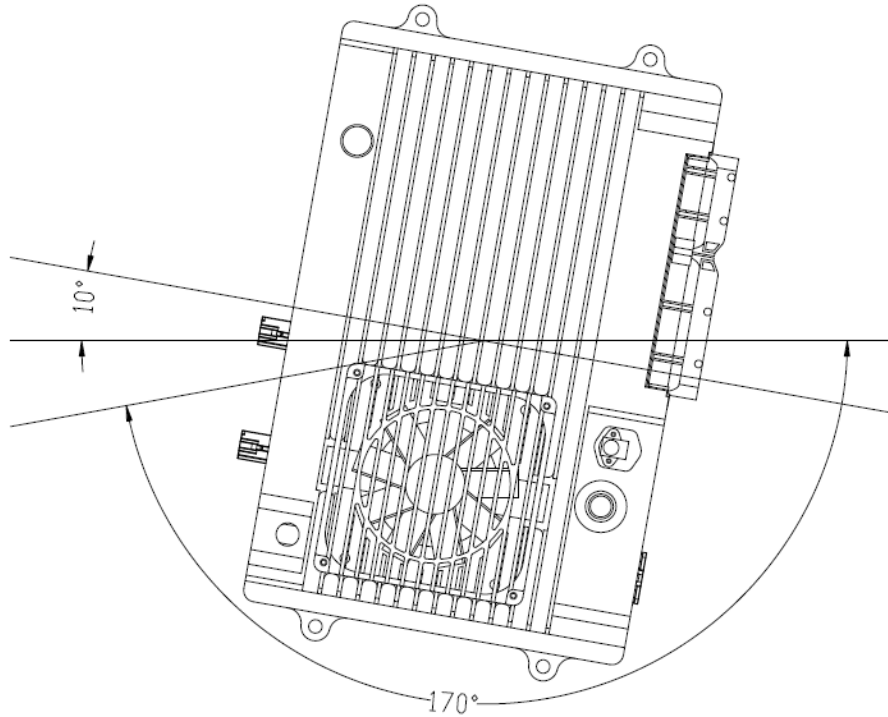

Ecotron recommends using the four built-in mounting points of the ADCU for installation and fixation. The mounting bracket is recommended to be made of metal, such as aluminum alloy, and the ADCU casing should have reliable electrical connection to the vehicle body through the bracket. If other material is used, the customer must ensure that they meet the ADCU's requirements for vibration, heat dissipation, temperature, EMC, and other factors. Any deviations should be confirmed with Ecotron's engineering team.

- 9) For Harness installation, high-speed signal lines such as network cables and video cables should, as much as possible, be routed away from high-voltage or high-interference areas such as motors, battery packs, and DC-DC converters.