



EV22297A03 Datasheet

Contact us:

Web: <http://www.ecotron.ai>

Email: info@ecotron.ai
support@ecotron.ai

Address: 13115 Barton Rd, STE H
Whittier, CA, 90605
United States

Tel: +1 562-758-3039
+1 562-713-1105

Table of Contents

CHAPTER 1 GENERAL INFORMATION	4
1.1 Introduction.....	4
1.1.1 Functionality.....	4
1.1.2 Mechanical Properties.....	5
1.1.3 Processor Specs.....	6
1.1.4 Power Supply	6
1.1.5 Bootloader.....	6
 CHAPTER 2 TECHNICAL PERFORMANCE	 7
2.1 Electrical Characteristics	7
2.2 Electrical Performance Standard	8
2.3 Environmental Standards.....	9
2.4 EMC Test Standard	10
 CHAPTER 3 INSTALLATION REQUIREMENTS	 11

Chapter 1 General Information

1.1 Introduction

VCU (Vehicle Control Unit) is the master controller for electric and hybrid vehicles. VCU is responsible for the vehicle's power system energy management, power mode management, and electrical auxiliary control. Its core functions include power on/off management, power system management, drive mode management, drive and brake control, auxiliary management, and fault diagnosis.

1.1.1 Functionality

EV22297A03 has the following functions:

Table 1.1.1.1 EV22297A03 Features

Feature
1 Key switch (KEYON)
1 Hardwire wakeup (WAKEUP)
4 Power supply (BATT)
9 5V Outputs
6 CAN Bus ports: CANA, CANB, CANC, CAND support ISO CANFD. CANE, CANF support CAN 2.0A/B and specific frame wake up
1 LIN Bus port
2 FlexRay Bus port
13 Digital signal inputs: 2 channels active high, 11 channels active low
22 Analog signal inputs: 8 channels of 0-5V voltage type input, 6 channels of 0-5V resistor type input, and 8 channels of 0-32V voltage type input
4 Frequency signal inputs
10 High-side driver outputs
26 Low-side driver outputs: 7 configurable as PWM outputs
Hardware watchdog

1.1.2 Mechanical Properties

The housing of VCU is formed by aluminum die-casting and sealed with silicone rubber. There is no special treatment or plating on the outside of the housing, no sharp burrs, and sharp edges. The nominal dimensions of the VCU housing are as follows (excluding the female end of the VCU connector, in mm):

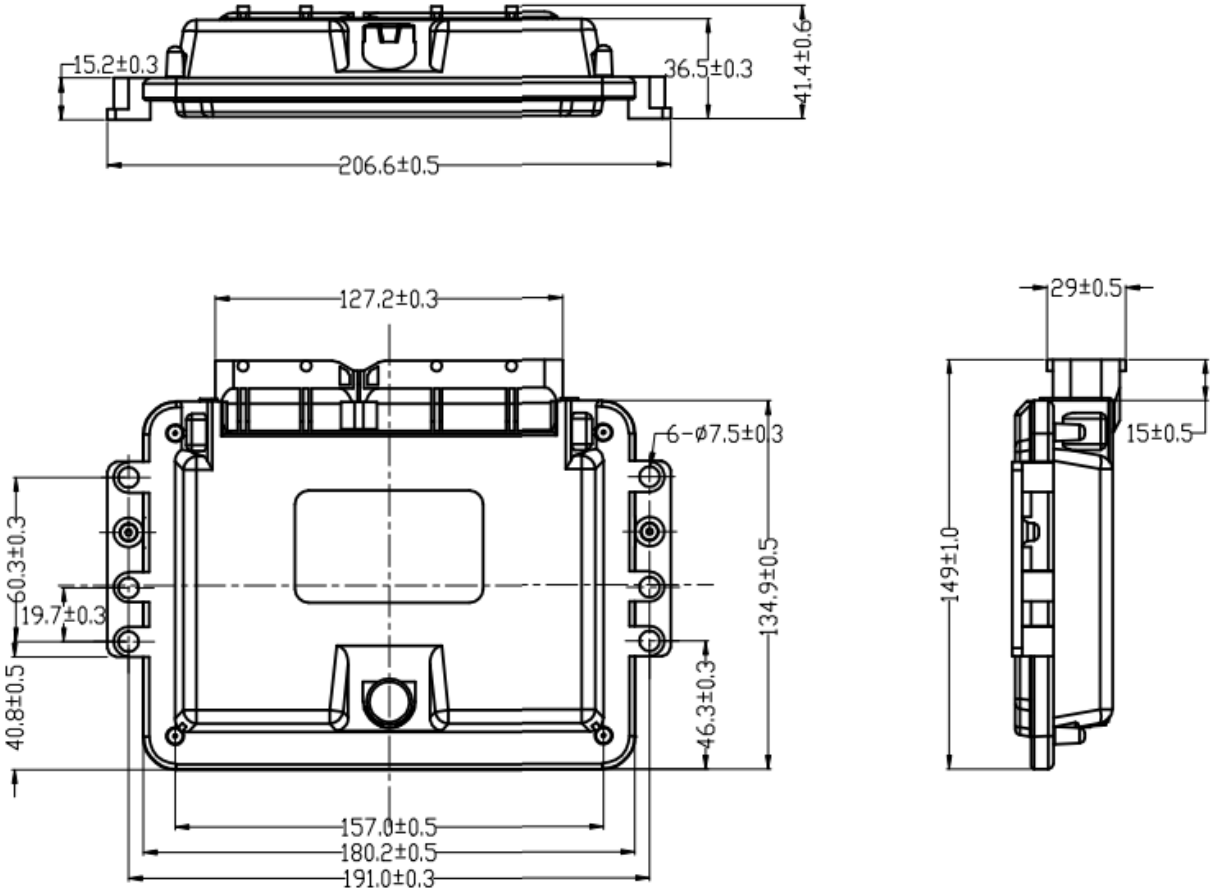

Figure 1 VCU Housing Size

The appearance of the housing is as follows:



Figure 2 VCU Housing Appearance

Copyright ECOTRON CORPORATION
All Rights Reserved

Please use Torx T15 screwdriver to disassemble and assemble the housing.
 The product identification label is affixed to the VCU housing, which contains the product identification code, customer information, date, batch number, serial number, etc.
 Ecotron VCU, uses automotive grade connectors, which meet the automotive safety requirements and have 121 pins.

1.1.3 Processor Specs

Table 1.1.3.1 Processor Specs

Feature	Detail
Micro Control Core	32-bit Infineon TC297TP
Maximum Frequency	300MHZ
Flash	8M
SRAM	728K
EEPROM	512Kbit
SBC	TLF35584QVVS2

1.1.4 Power Supply

EV22297A03 requires 4 channels of continuous power supplies, and the VCU is powered on through the key switch.

1.1.5 Bootloader

The EV22297A03 bootloader supports the UDS protocol by factory default.

Chapter 2 Technical Performance

2.1 Electrical Characteristics

Item	Design Specifications
Operating Voltage	DC 12 V / 24v (9~32v)
Operating Temperature	-40 °C ~85 °C
Working Humidity	0~95%, No Condensation
Storage Temperature	-40 °C ~85 °C
Quiescent Current	<1mA
Rated Power Consumption	3 W (Not Including Load)
Protection Level	IP67
Weight	≤ 700g
Controller Size	207×150×42mm
Material	Die-Cast Aluminum
Housing	Equipped with waterproof ventilation valve, Good Heat Dissipation

2.2 Electrical Performance Standard

Item	Test Standard
Direct Current Supply Voltage	ISO 16750-2
Overvoltage (12V, High Temperature)	ISO 16750-2
Slow Decrease and Increase of Supply Voltage	ISO 16750-2
Superimposed Alternating Voltage	ISO 16750-2
Reversed Voltage	ISO 16750-2
Low Voltage Reset Features	ISO 16750-2
Low Voltage Start Features	ISO 16750-2
Open Circuit Tests – Single Line Interruption	ISO 16750-2
Open Circuit Tests – Multiple Line Interruption	ISO 16750-2
Short Circuit Protection	ISO 16750-2
Withstand Voltage	ISO 16750-2
Insulation Resistance	ISO 16750-2

2.3 Environmental Standards

Item	Test Standard
Waterproof (IP67)	IEC/EN 60529
Dustproof (IP67)	ISO 20653
Salt Spray Leakage Function and Corrosion Test	ISO 16750-4
Mechanical Shock Test	ISO 16750-3
Vibration Test	ISO 16750-3
Drop Test	ISO 16750-3
Temperature Shock	ISO 16750- 4
Electrical Operation at Circulating Ambient Temperature	ISO 16750-4
High and Low Temperature Operation Experiment	ISO 16750-4
High and Low Temperature Experiment	ISO 16750-4
Temperature and Humidity Cycle	IEC 60068-2-30
Constant Temperature and Humidity	ISO 16750-4

2.4 EMC Test Standard

Item	Test Standard
Voltage Transient Emissions Test	ISO7637-2
Conducted Emission (CE-V)	CISPR25
Conducted Emission (CE-C)	CISPR25
Radiation Emission (RE-ALSE)	CISPR25
Radiation Immunity Experiment (I/O)-ICC	ISO7637-3
Radiation Immunity Experiment BCI-Substitution Method	ISO11452-4
Radiation Immunity Experiment (RI)	ISO11452-2
Low Frequency Magnetic Field Immunity	ISO11452-8
ESD	ISO10605

Chapter 3 Installation Requirements

It is recommended to install the VCU in the cockpit. If the OEM wants to assemble the VCU in another location, Ecotron's engineers and the OEM's engineers should evaluate the corresponding installation location together.

The precautions for VCU installation are as follows:

1. The VCU and wiring harness installation should be firm and reliable, and there should be no looseness. Avoid supporting the wiring harness by VCU. At the same time, the arrangement of the VCU wiring harness should prevent and protect all wires in the wiring harness from damage due to wear and to overheat.
2. Try to avoid installing in places where dust is easy to gather. A large amount of dust accumulation will affect the reliability of VCU work.
3. VCU should keep away from the location where the temperature of the housing itself may exceed 85°C. At the same time, it is necessary to prevent the surrounding parts from releasing heat to the VCU.
4. Avoid installing the VCU in locations where oil, moisture, and water droplets are likely to splash on it.
5. Avoid the possibility of additional mechanical shock and external impact due to the installation position and fixing method of the VCU and avoid installing the VCU at the resonance point of the car body.
6. Avoid installing the VCU where it may come into contact with the battery or other parts that are prone to seepage of acid and alkaline solutions and near the VCU power terminal.
7. VCU should be installed in the horizontal and vertical position according to the connector downwards and maintain a certain angle to prevent water from entering the connector. In the horizontal direction, the recommended installation angle is -170° to -10° , as shown in Figure 13 below. In the vertical direction, the recommended installation angle is -170° ~ -10° , as shown in Figure 14 below.

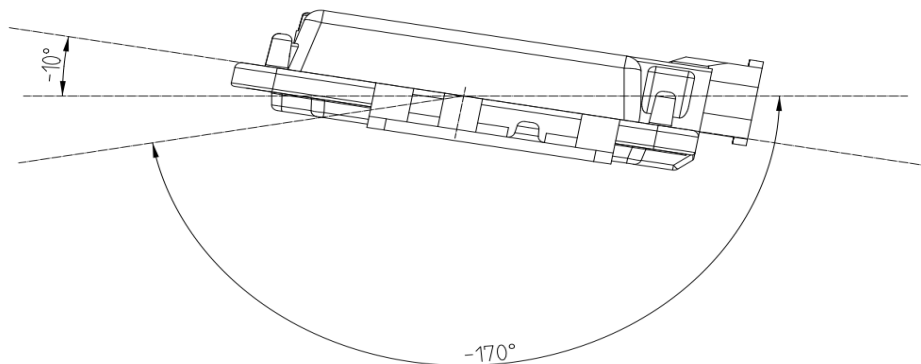

Figure 13 Horizontal Installation Angle

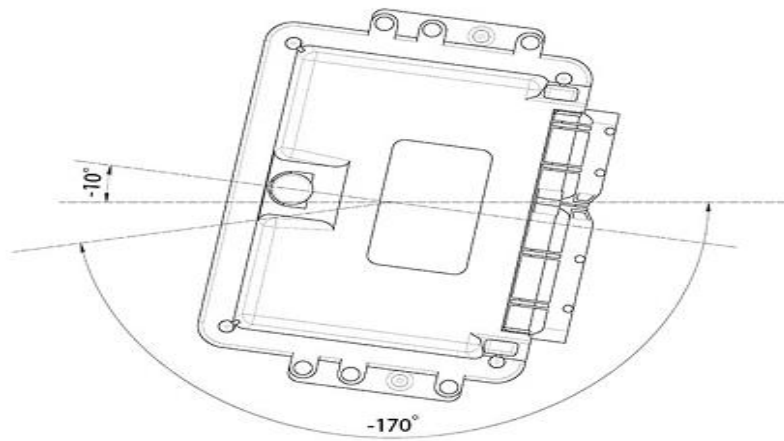
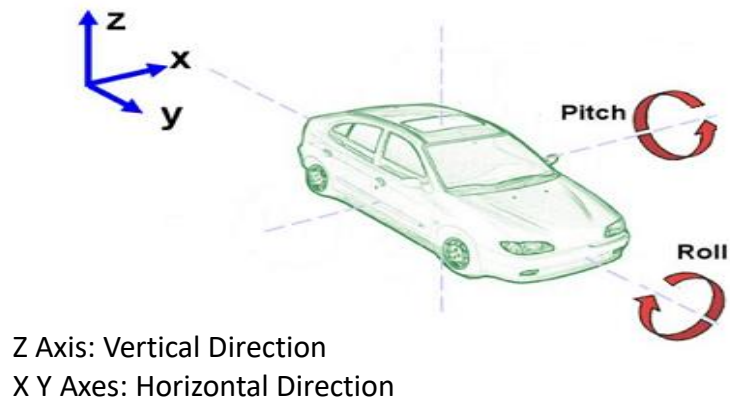

Figure 14 Vertical Installation Angle

Ecotron recommends using the six mounting holes on the VCU for installation. It is recommended to use metal materials such as aluminum alloy for the mounting bracket. The housing should have a reliable electrical connection with the vehicle body through the bracket. If other materials are used, the customer must ensure that they can meet the requirements of VCU for vibration, heat dissipation, temperature, EMC, etc. If there is any deviation, it needs to be confirmed with Ecotron.

The VCU connects to ground through the vehicle's body. The specific requirement is to directly connect the ground wire in the wiring harness to the vehicle's body and ensure reliable electrical connections.