



EF22297B02 Datasheet

Contact Us:

Web: <http://www.ecotron.ai>

Email: info@ecotron.ai
support@ecotron.ai

Address: 13115 Barton Rd, Ste H
Whittier, CA 90605
United States

Tel: +1 562-758-3039
+1 562-713-1105

Table of Contents

CHAPTER 1 SYSTEM INTRODUCTION	4
1.1 Functions.....	4
1.2 Mechanical Properties	4
1.3 Tech Specs	7
1.4 Power Supply.....	7
1.5 Description of Bootloader	7
 CHAPTER 2 TECHNICAL PERFORMANCE	 8
2.1 Electrical Characteristic Parameters.....	8
2.2 Electrical Performance Test Standards	9
2.3 Environmental Test Standards	10
2.4 EMC Test Standards	11
 CHAPTER 3 INSTALLATION REQUIREMENTS	 12

Chapter 1 System Introduction

FCU (Fuel cell Control Unit) is a control unit designed to control fuel cells.

1.1 Functions

EF22297B02 has the following functions:

Feature
1 – key signal (KEYON)
1 – hard-wired wake-up signal (WAKEUP)
4 – supply voltage (BATT1)
9 – 5V output
4 – CAN communication interface (supports CAN flashing): specific frame wake-up supported on CANA, and CANFD supported on CANB, CANC, CAND
2 – H-bridge output
1 – LIN communication interface
8 – digital signal input: 4 Active-high, 4 Active-low
22 – analog signal input:
12 – channels 0~5V voltage type input
10 – channels 0~5V resistor type input
6 – frequency signal input
9 – high-side driver control output: 5 can be configured as PWM output
22 – low-side driver control output: 10 can be configured as PWM output
4 – Peak and Hold
Hardware watchdog

1.2 Mechanical Properties

The housing of the FCU made from die-cast aluminum and assembled with a silicone seal. There is no special treatment or plating on the outside of the housing, no sharp burrs, and sharp edges.

The nominal dimensions of the housing shape of the FCU are as follows (excluding the female end of the FCU connector, in mm):

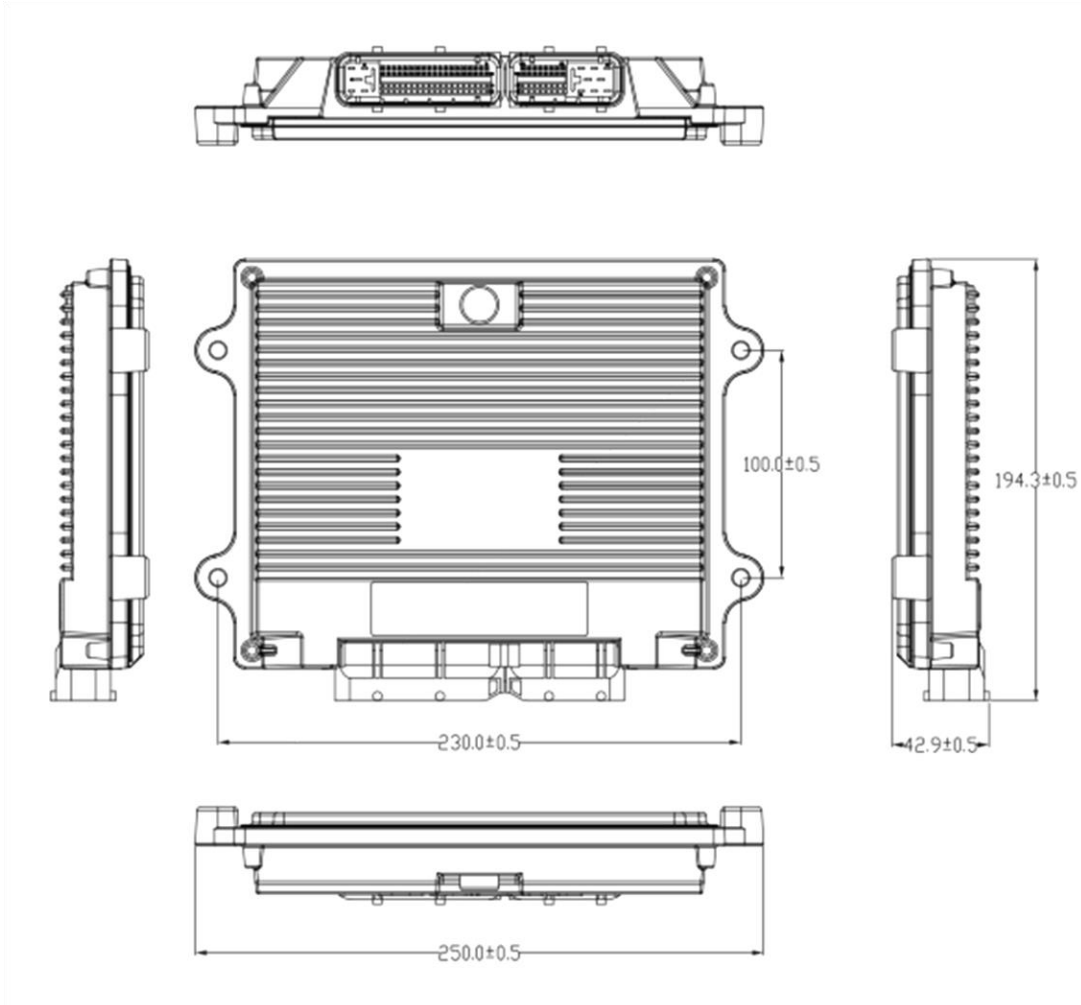

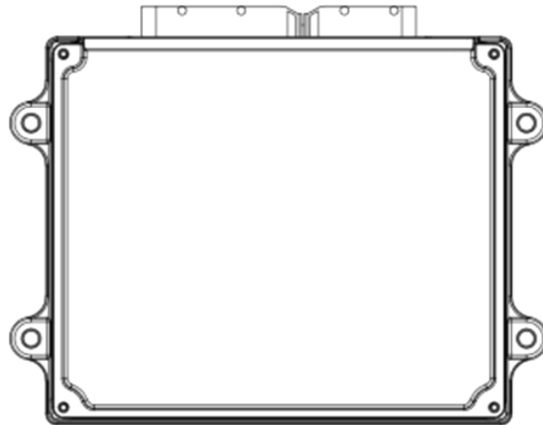

The appearance of the housing is as follows:



Please use Torx T15 screwdriver to disassemble and assemble the housing. The FCU housing is affixed with a product identification label containing the product identification code, including customer information, production date, batch number, serial number, etc. Ecotron VCU, uses automotive grade connectors, which meet the automotive safety requirements and have 121 pins.

1.3 Tech Specs

Feature	Detail
Micro Control Core	32-bit Infineon TC297TP
Maximum Frequency	300MHz
Flash	8M
SRAM	728K
SPI Serial EEPROM	64KB
Float Point Capability	Yes
SBC Microprocessor	TLF35584QVVS2

1.4 Power Supply

The EF22297B02 requires four continuous power supplies to power up the FCU via a key switch.

1.5 Description of Bootloader

The EF22297B02 bootloader supports UDS protocol by factory default.

Chapter 2 Technical Performance

2.1 Electrical Characteristic Parameters

Characteristic	Design Specification
Operating Voltage	DC 12/24V (9~32V)
Operating Temperature	-40~85 °C
Operating Humidity	0~95%, no condensation
Storage Temperature	-40~85 °C
Quiescent Current	<1mA
Rated Power Consumption	3W (not including load power)
Protection Level	IP67
Weight	≤700g
Dimensions	250×194×37mm
Housing Material	Die-cast Aluminum
Housing Characteristics	Equipped with waterproof ventilation valve, good heat dissipation

2.2 Electrical Performance Test Standards

Item	Test Standard
DC Supply Voltage	ISO 16750-2
Overvoltage (12V, high temperature)	ISO 16750-2
Supply Voltage Ramp Down and Ramp Up	ISO 16750-2
AC Voltage Superposition Test	ISO 16750-2
Reverse Voltage	ISO 16750-2
Low Voltage Reset Feature	ISO 16750-2
Low Voltage Startup Feature	ISO 16750-2
Open Circuit Experiment - Single-Line Interruption	ISO 16750-2
Open Circuit Experiment - Multi-Line Interruption	ISO 16750-2
Short Circuit Protection	ISO 16750-2
Withstand Voltage	ISO 16750-2
Insulation Resistance	ISO 16750-2

2.3 Environmental Test Standards

Item	Test Standard
Waterproof (IP67)	IEC/EN 60529
Dustproof (IP67)	ISO 20653
Salt Spray Leak Function and Corrosion Test	ISO 16750-4
Mechanical Vibration Shock Test	ISO 16750-3
Vibration Test	ISO 16750-3
Drop Test	ISO 16750-3
Temperature Shock	ISO 16750-4
Electrical Operation at Cycling Ambient Temperatures	ISO 16750-4
High and Low Temperature Operation Experiment	ISO 16750-4
High and Low Temperature Experiment	ISO 16750-4
Temperature and Humidity Cycle	IEC 60068-2-30
Constant Temperature and Humidity	ISO 16750-4

2.4 EMC Test Standards

Item	Test Standard
Transient Conducted Emission	ISO 7637-2
Conducted Emission Experiment CE-V	CISPR25
Conducted Emission Experiment CE-C	CISPR25
Radiation Emission Experiment RE-ALSE Method	CISPR25
Radiation Immunity Test (I/O)-ICC Method	ISO 7637-3
Radiated Immunity Test BCI-substitution Method	ISO 11452-4
Radiation Immunity Experiment RI	ISO 11452-2
Low Frequency Magnetic Field Immunity	ISO 11452-8
Electrostatic Discharge (ESD)	ISO 10605

Chapter 3 Installation Requirements

It is recommended to install the FCU in the cockpit. If the OEM wants to assemble the FCU in another location, Ecotron's engineers and the OEM's engineers should evaluate the corresponding installation location together.

Precautions for FCU installation are as follows:

- 1) The installation of FCU and harness shall be firm and reliable without looseness, and please avoid supporting the harness through FCU. At the same time, the layout of FCU harness shall prevent and protect all wires in the harness from damage due to wear and overheating.
- 2) Try to avoid installing in the place where dust is easy to gather. A large amount of dust accumulation will affect the reliability of FCU work.
- 3) It shall be kept away from the position where the temperature of its shell may exceed 85 ° C as far as possible, and the heat released by surrounding parts shall be prevented from radiating to FCU.
- 4) Avoid installing FCU in places where oil, moisture and water droplets are easy to splash.
- 5) Avoid the possibility of additional mechanical vibration and external force impact due to the installation position and fixing method of FCU and avoid installing FCU at the resonance point of vehicle body.
- 6) Avoid installing the FCU near the parts that may contact the battery or other acid-base solutions that are easy to seep out, and the places where the FCU is easy to be corroded.
- 7) Avoid installing the FCU near the positive terminal of the battery and the terminal of the ignition power supply.
- 8) The FCU shall be installed at a certain angle to avoid the inflow of water from the connector. In the horizontal direction, the recommended installation angle is - 170 ° to - 10 °. In the vertical direction, the recommended installation angle is - 170 ° ~ - 10 °. As shown in the figure below.

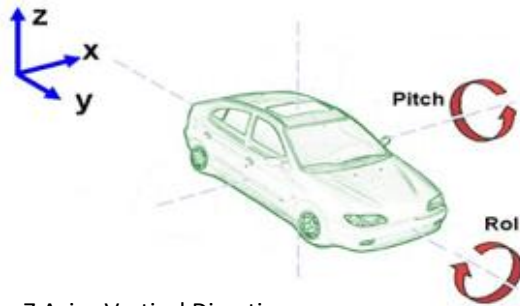
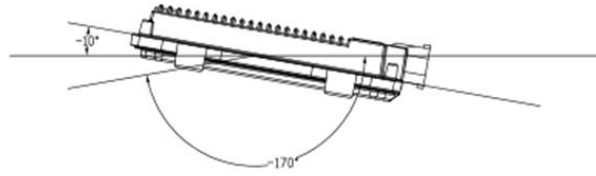

Z Axis : Vertical Direction
 X Y Axes : Horizontal Direction

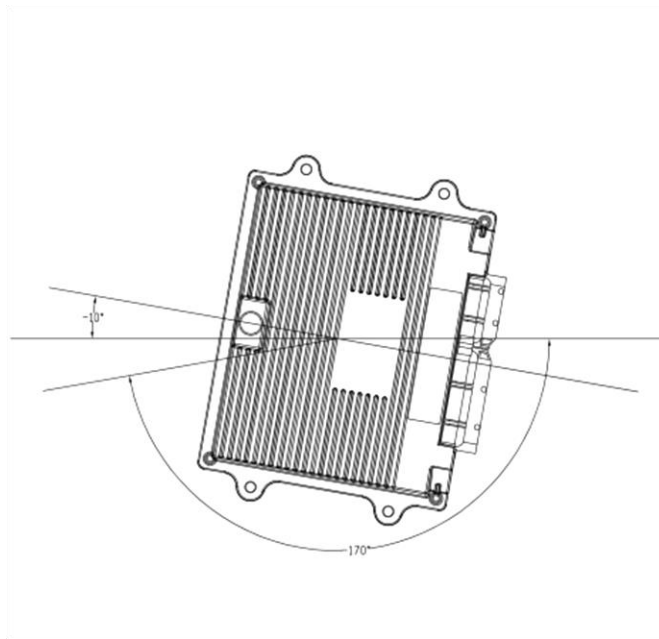

ECOTRON recommends using the four mounting holes on the FCU for installation. It is recommended to use metal materials such as aluminum alloy for the mounting bracket. The housing should have a reliable electrical connection with the vehicle body through the bracket.

If other materials are used, the customer must ensure that they can meet the requirements of FCU for vibration, heat dissipation, temperature, EMC, etc. If there is any deviation, it needs to be confirmed with ECOTRON.

The FCU system connects to ground through the vehicle's body. The specific requirement is to directly connect the ground wire in the wiring harness to the vehicle's body and ensure reliable electrical connections.